



Additive manufacturing across scales

John Hart

Mechanical Engineering, MIT

ajhart@mit.edu | mechanosynthesis.mit.edu

March 29, 2017





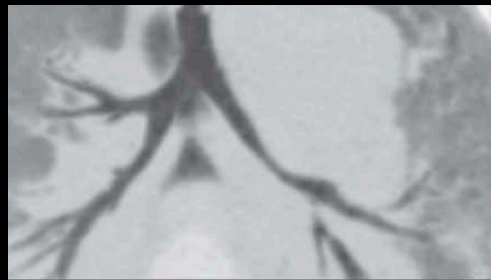
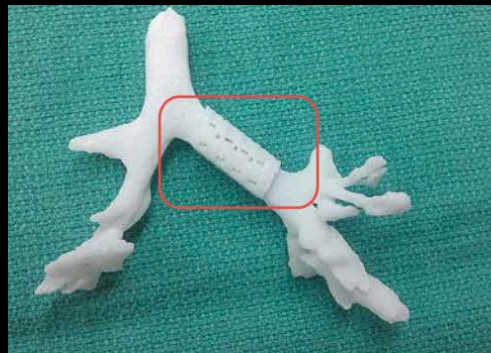

New materials and
computational intelligence

Relief printing (flexography)

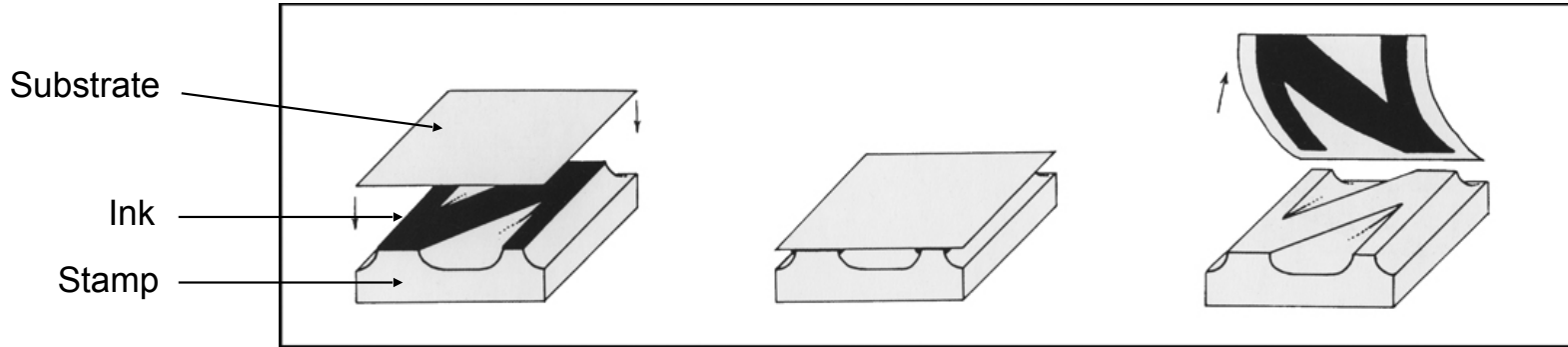
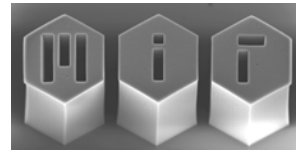

Wood stamps (200s ~ 1400s)



Hand print –
text, images, patterns

Metal stamps (1400s ~ 1900s)



Movable type printing –
mass-production of books

Rubber stamps (1900s ~ Present)

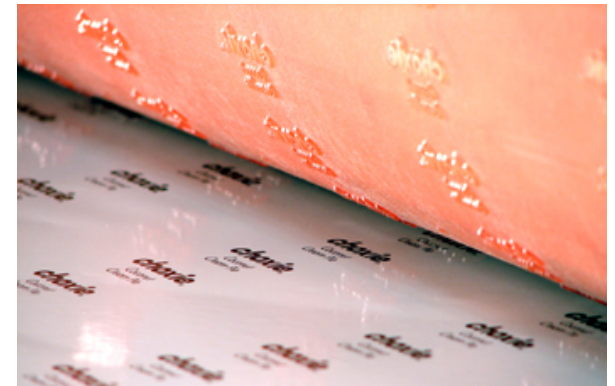

Roll-to-roll printing –
Low-cost, large-area graphics



Functional inks

- Inorganics: e.g., metal/oxide/semiconductor nanoparticles
- Organics: e.g., soluble conjugated polymers

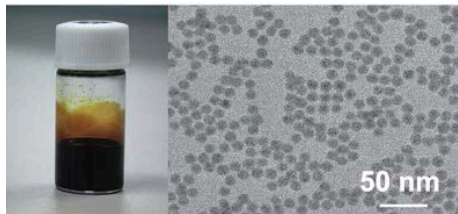

Conductive nanoparticle inks
[Tokito-Kumaki Lab]



Quantum dot dispersions
[Sigma-Aldrich Co.]



Conventional printing technologies



Printed electronics

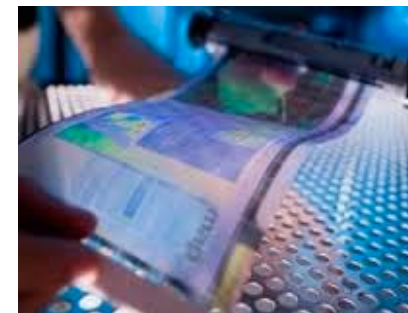

Flexible display [Printable Electronics Tech Center, UK]



Organic PV and lighting
[OE-A]



Smart labels

Flexographic Printing Process

Elastic printing plate with inked image elements

Printing substrate

Elastic printing plate

Hard Impression cylinder

Anilox roller

Ink supply

Cells of the anilox roller Ink-filled

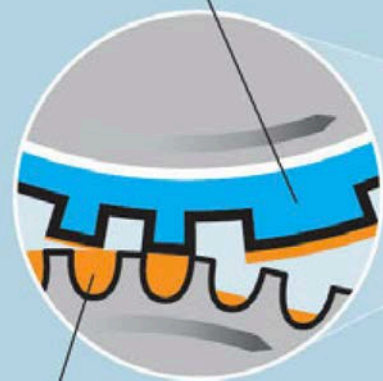

OE-A Roadmap 2015
Clemson University

https://www.youtube.com/watch?v=l_gh2fpC8Ew



Limitations of flexography

Ideal printing

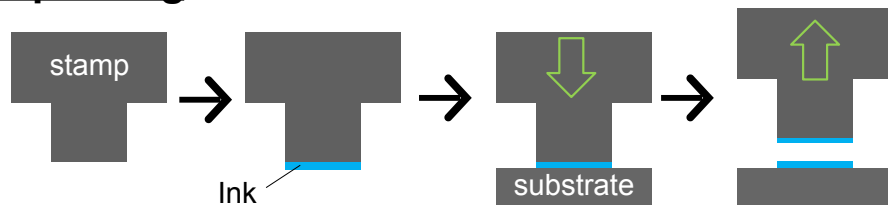

In reality

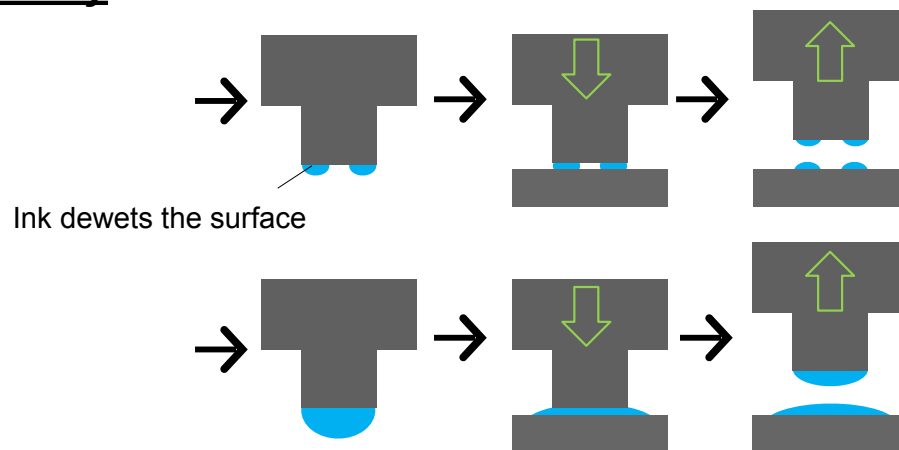

Film instability

Liquid spreading (+non-uniform drying)

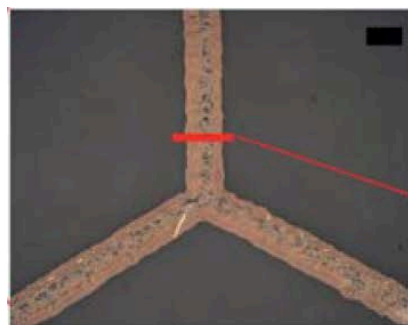

>> The resolution limit is not due to the manufacturability of small stamp features, but the difficulty of loading and transferring thin liquid films.

Flexographic (bottom) printed Ag NP ink [Yu et al., Nanoscale 2012]

Need: high resolution and throughput

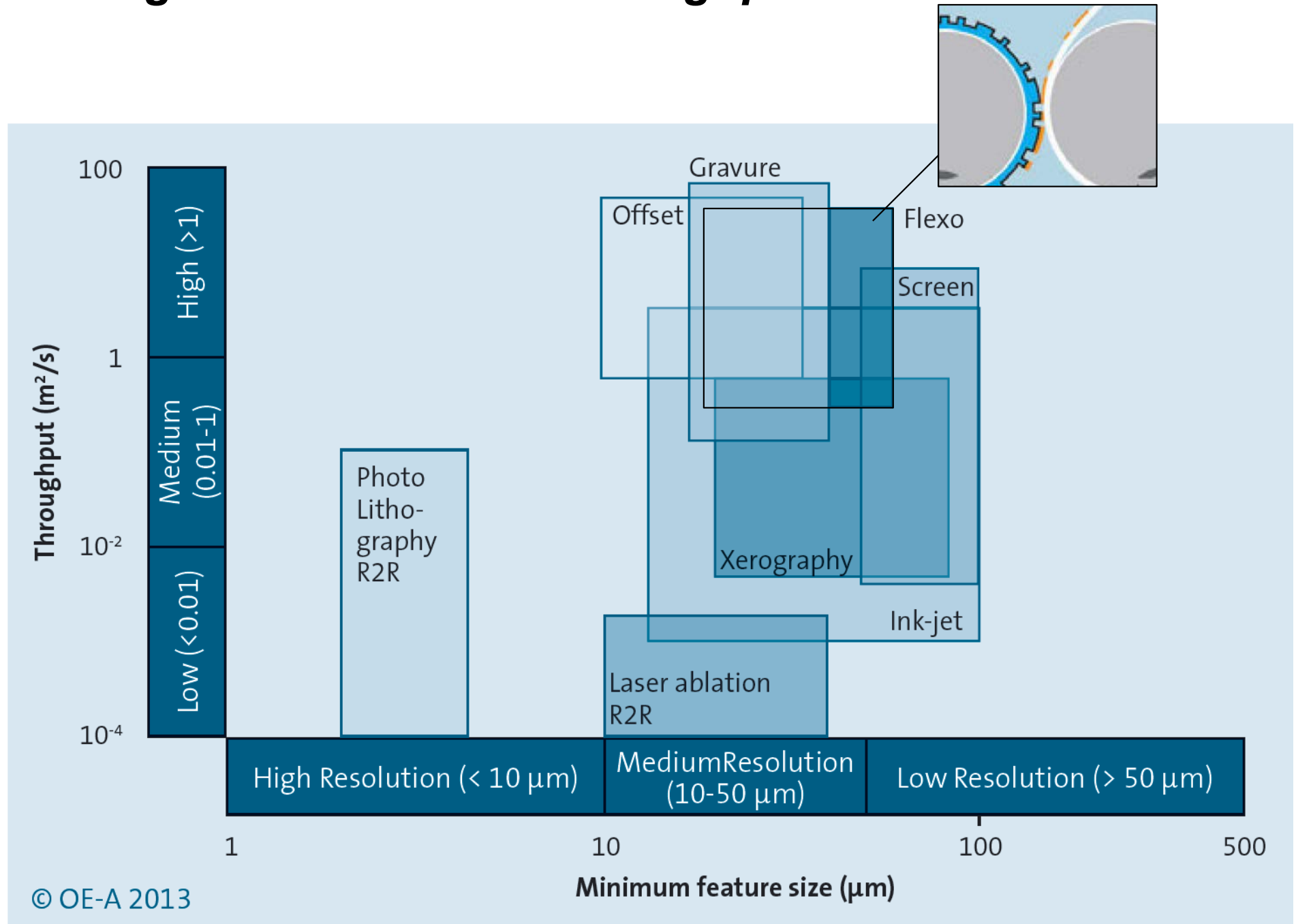

Ultrathin high-resolution flexography using *nanoporous* stamps



+ Hossein Sojoudi, Gareth Mckinley, Karen Gleason

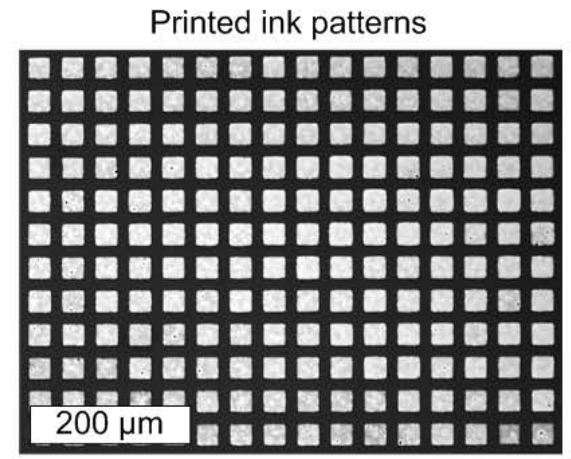
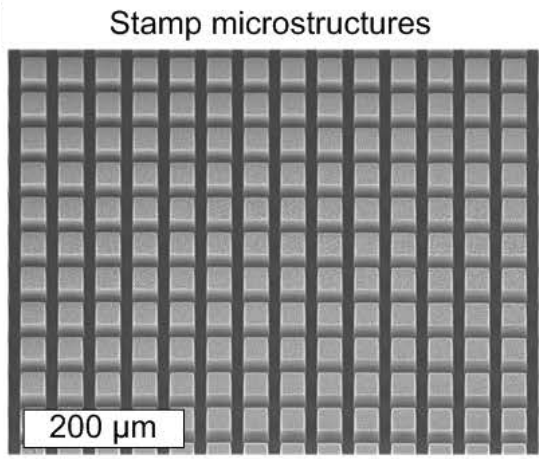
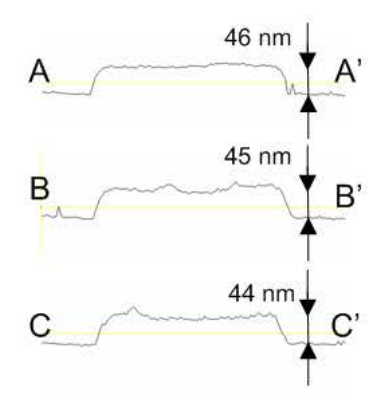
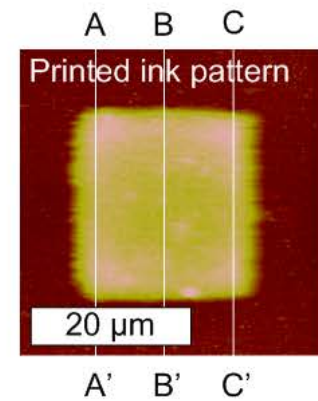
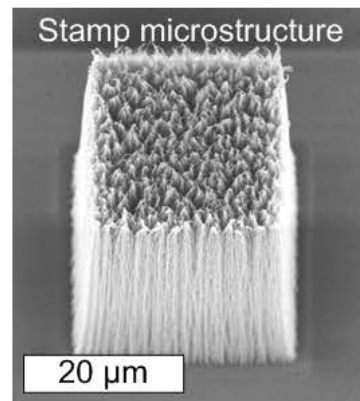
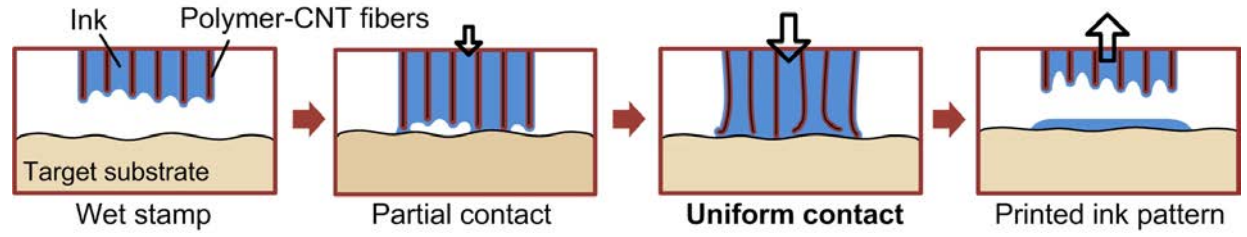
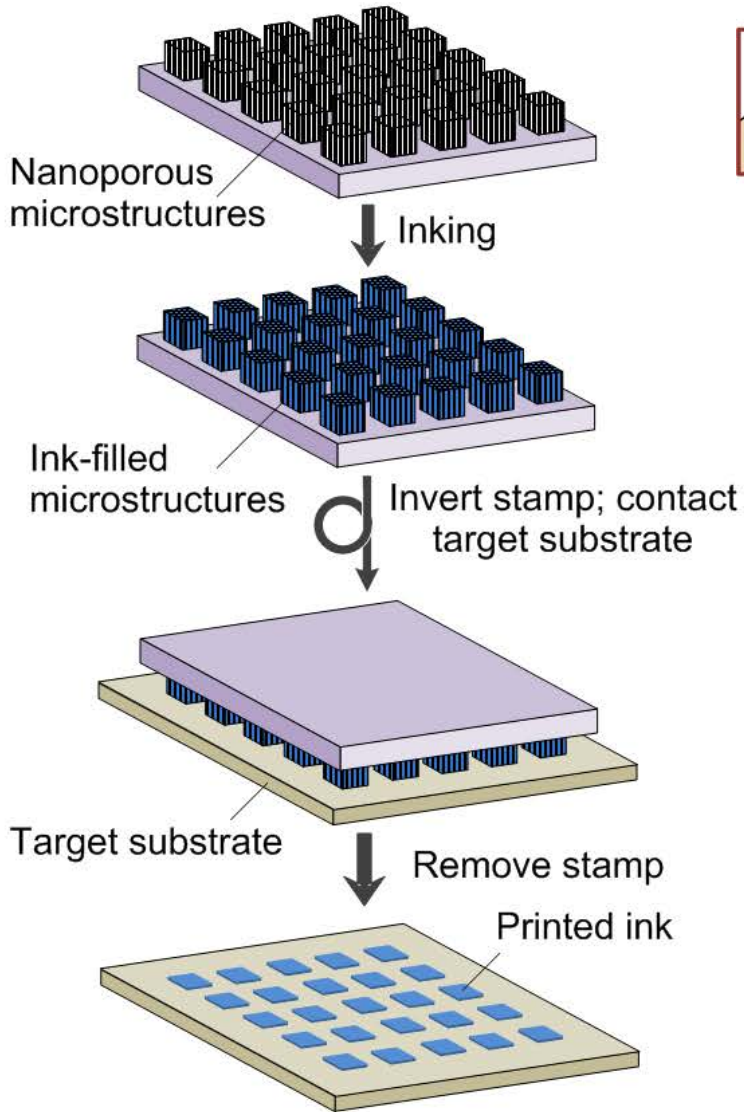

Silver nanoparticle ink (<10 nm, 50-60 wt% in tetradecane)

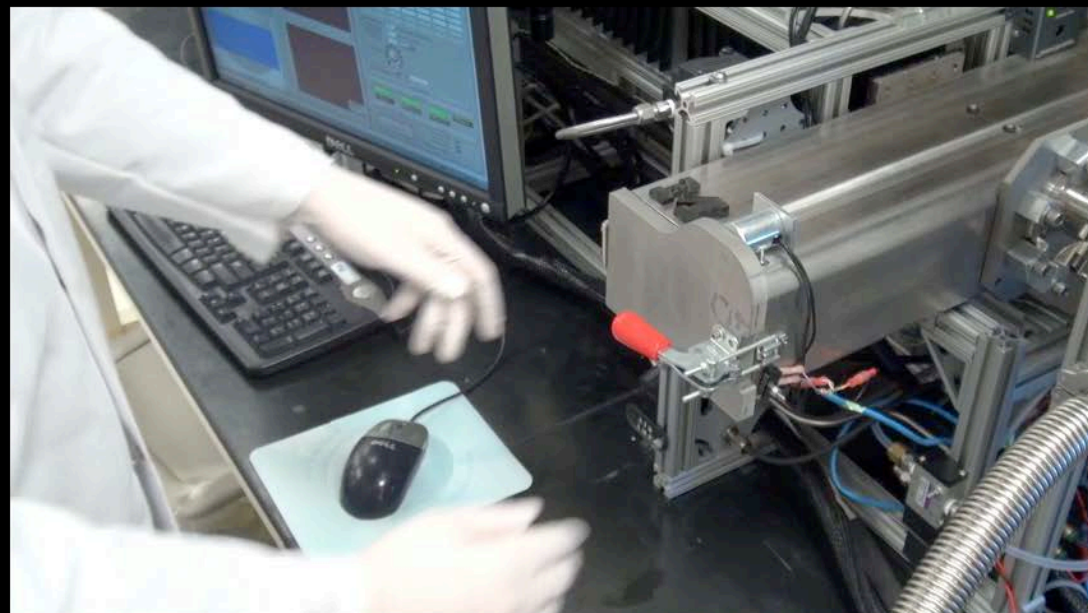
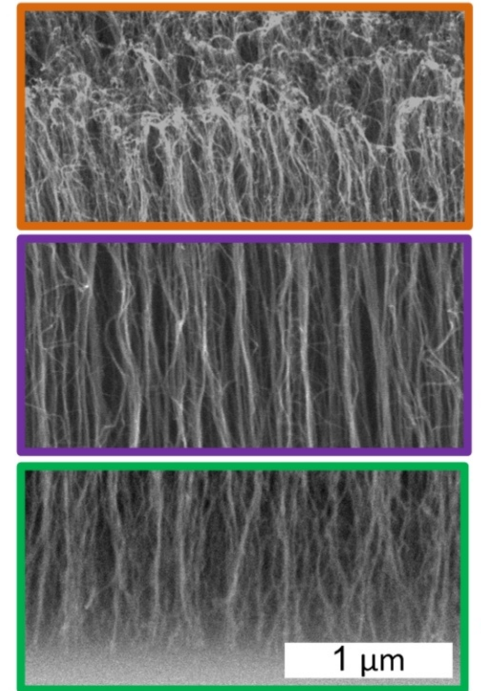
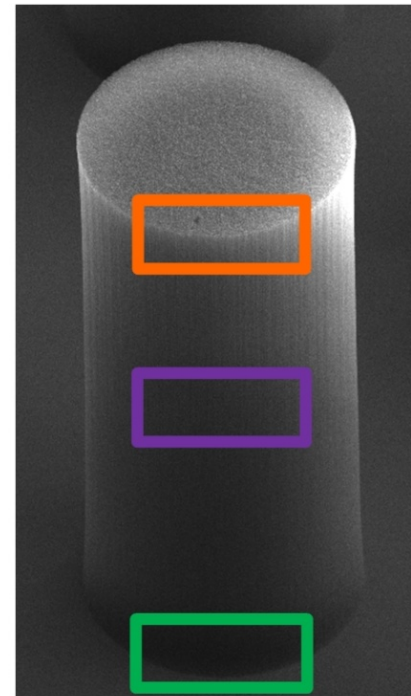
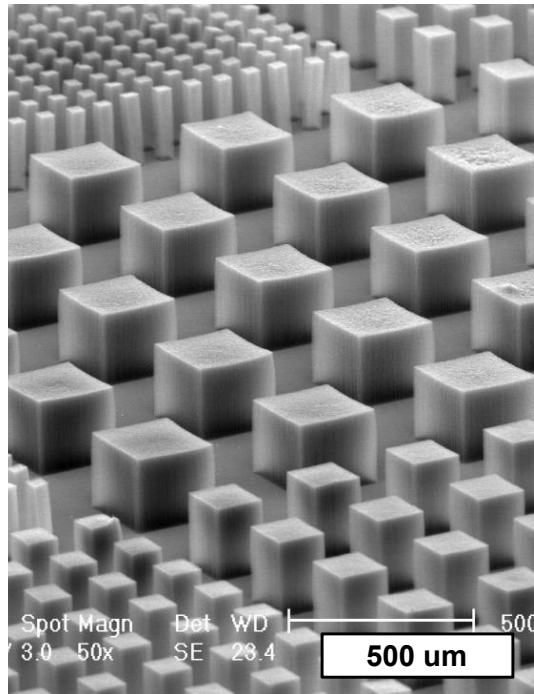
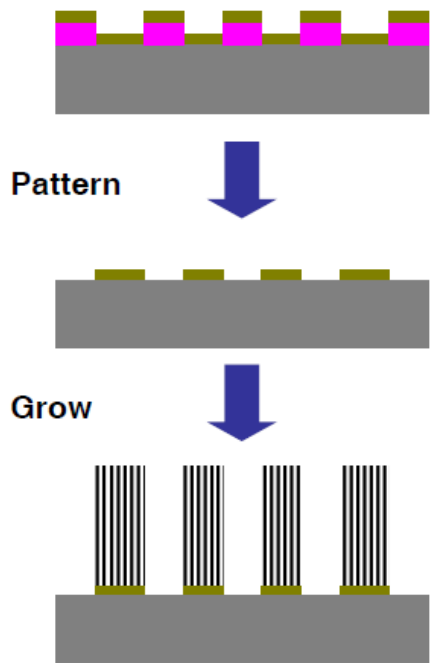



Fabrication of nanoporous stamps

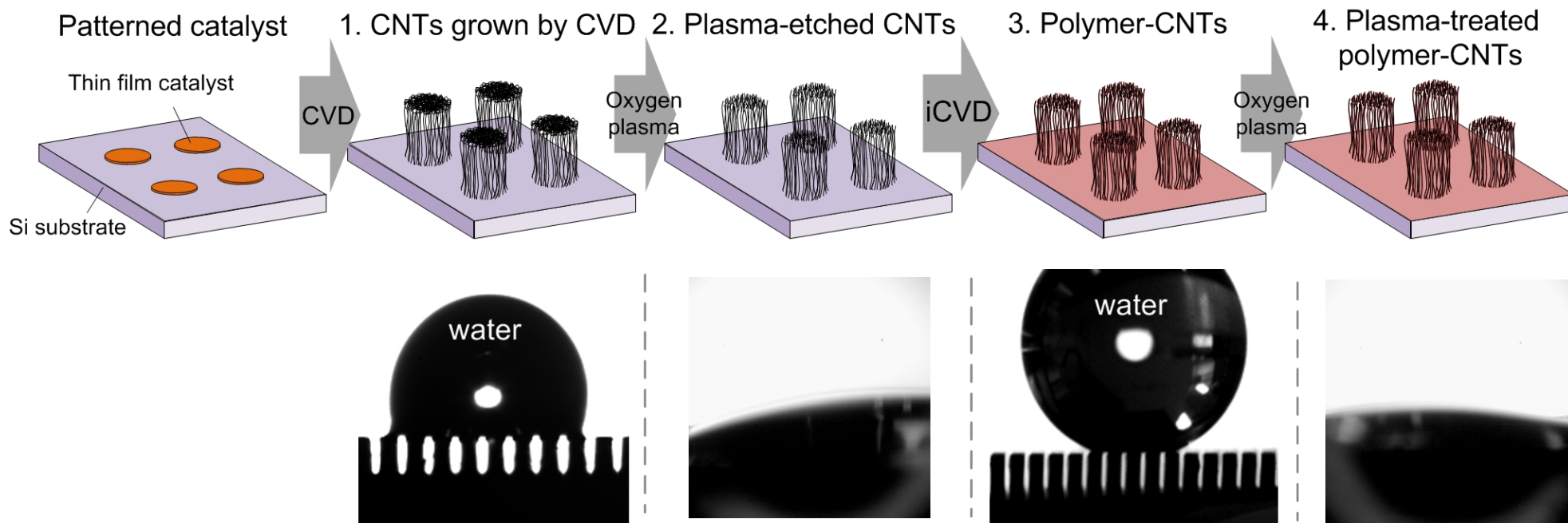

Surface (sharp indent)

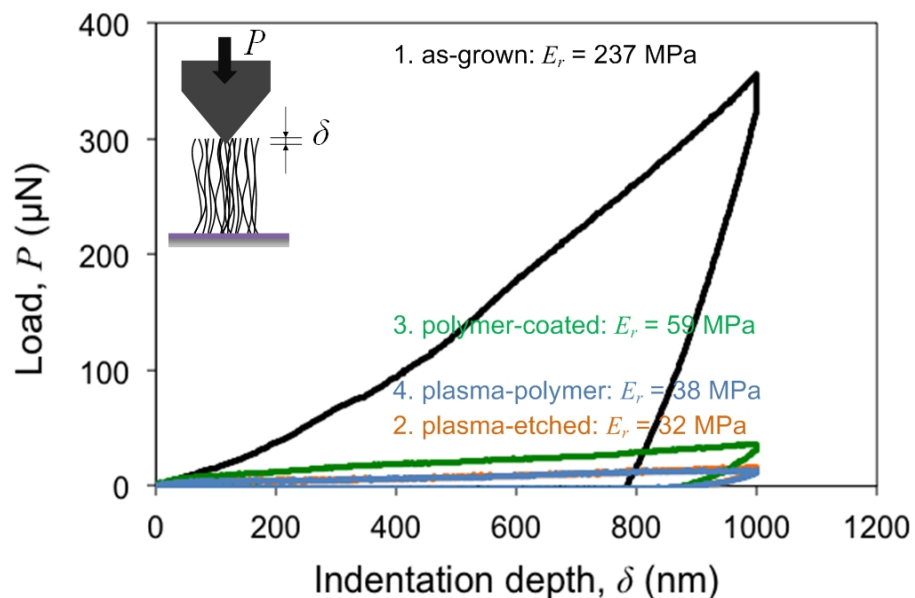

Bulk (flat indent)

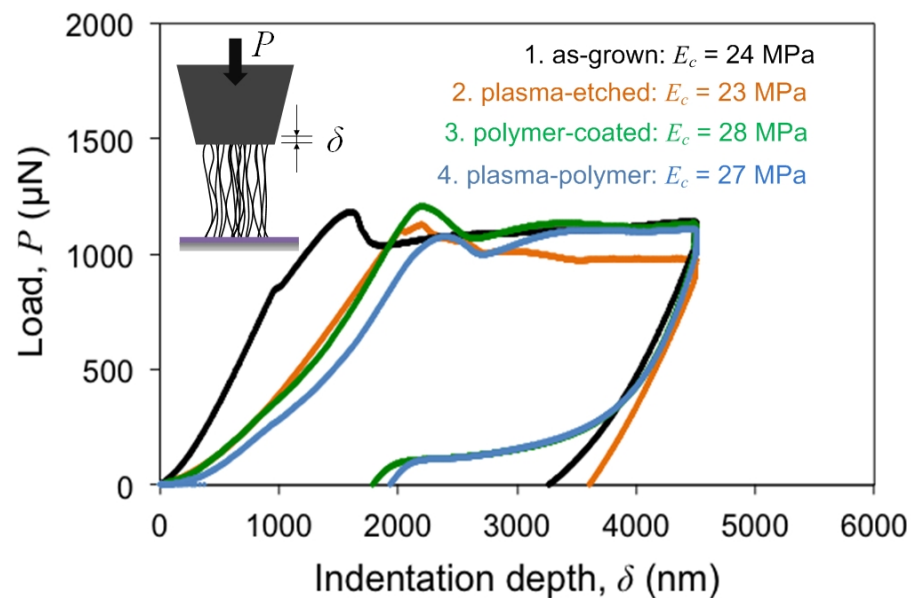

Printed metal (Ag) lines

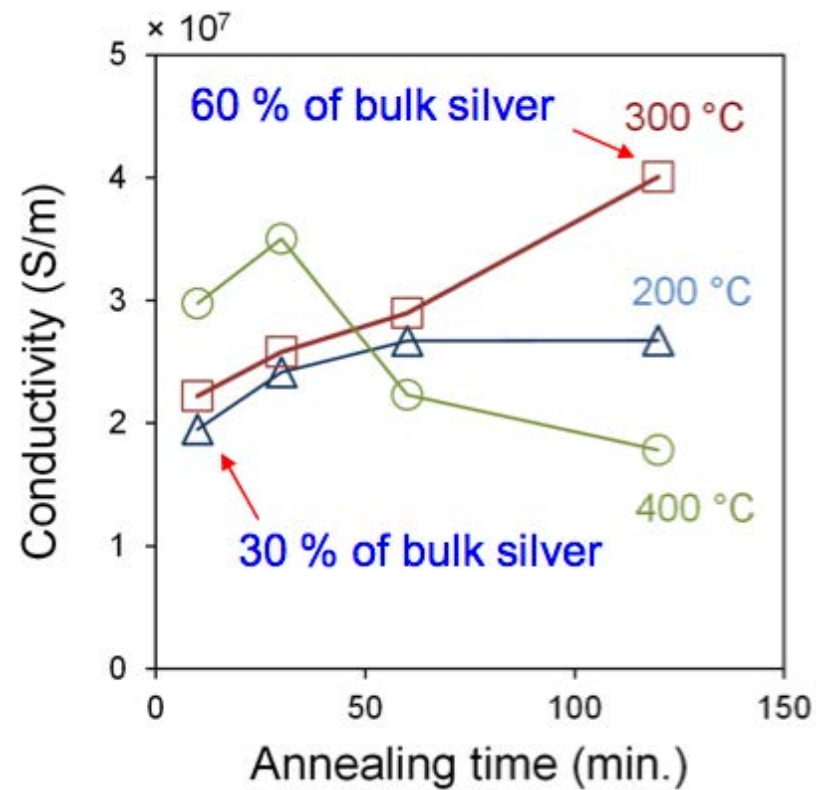
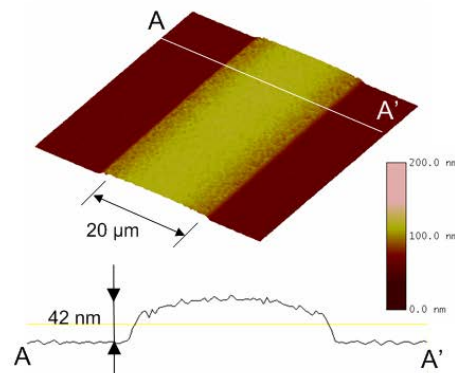
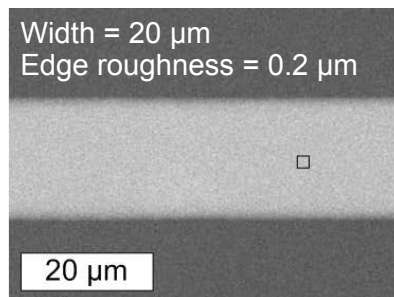
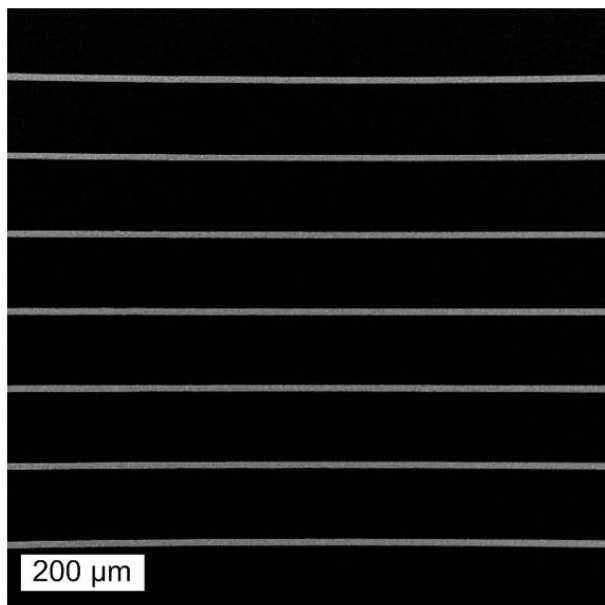
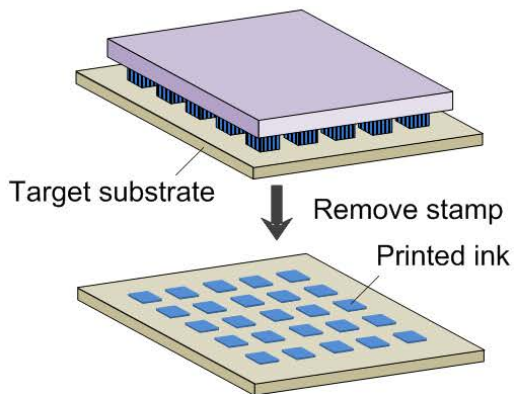

Continuous (plate-to-roll) flexoprinting

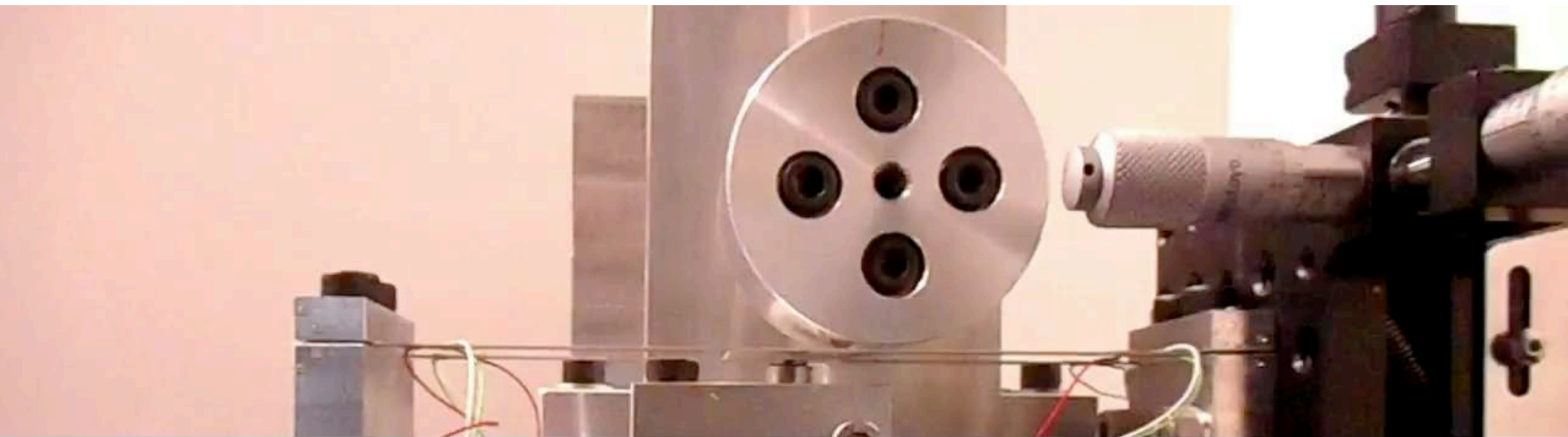
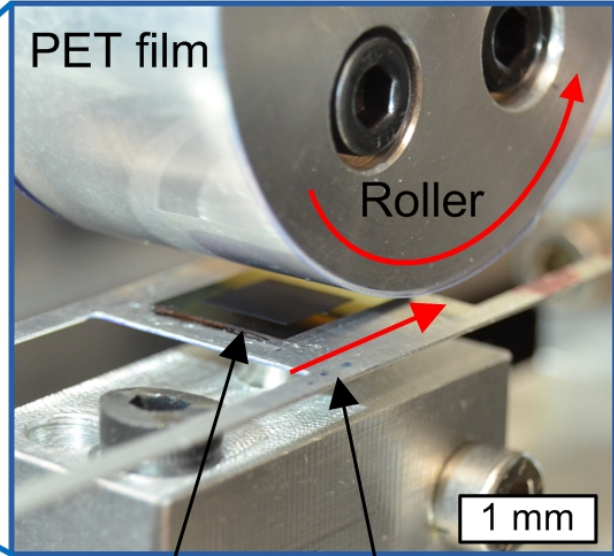
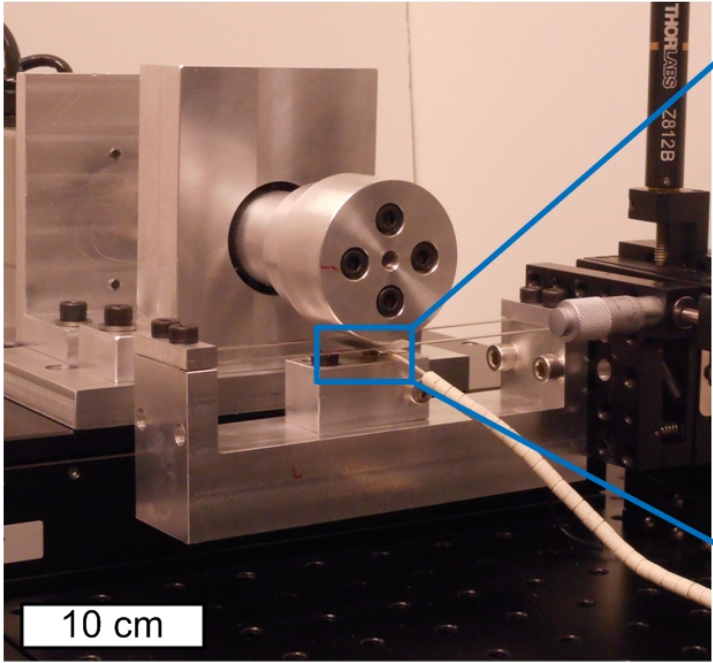

Printed transparent electrodes

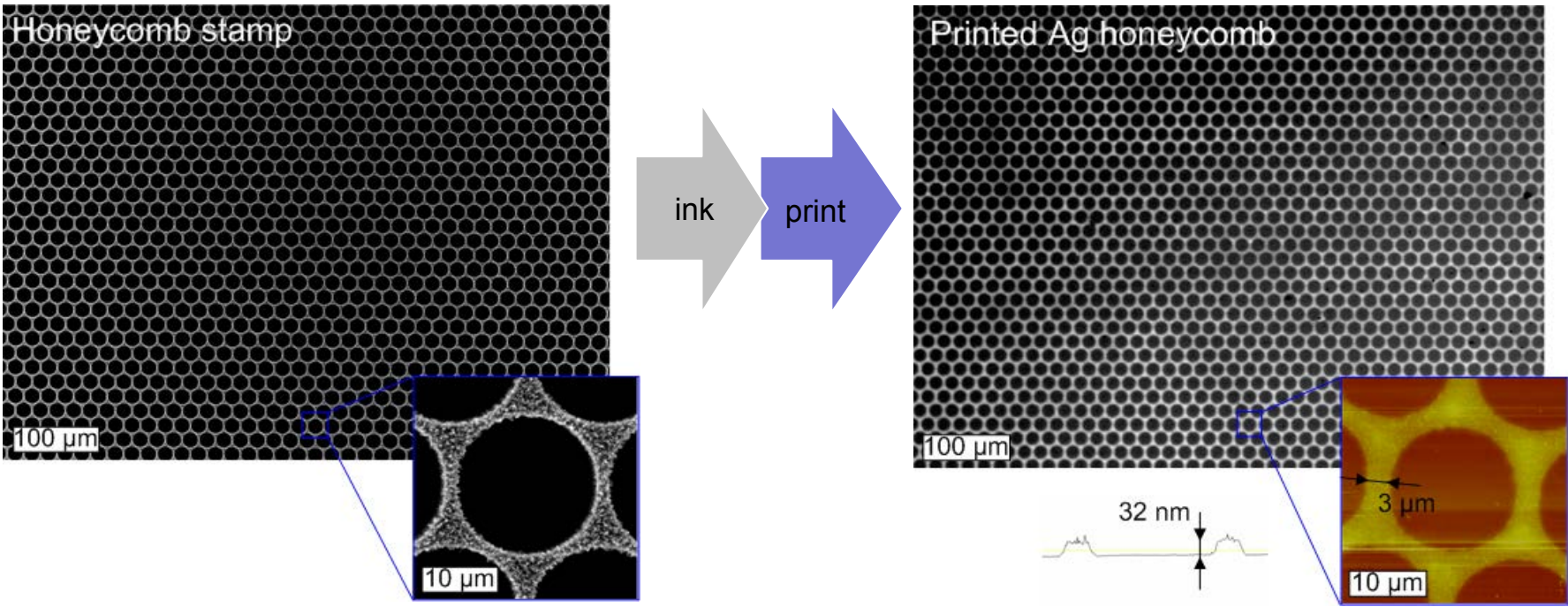

→90% transparency at 550 nm

3.6 Ohm/sq (after annealing)

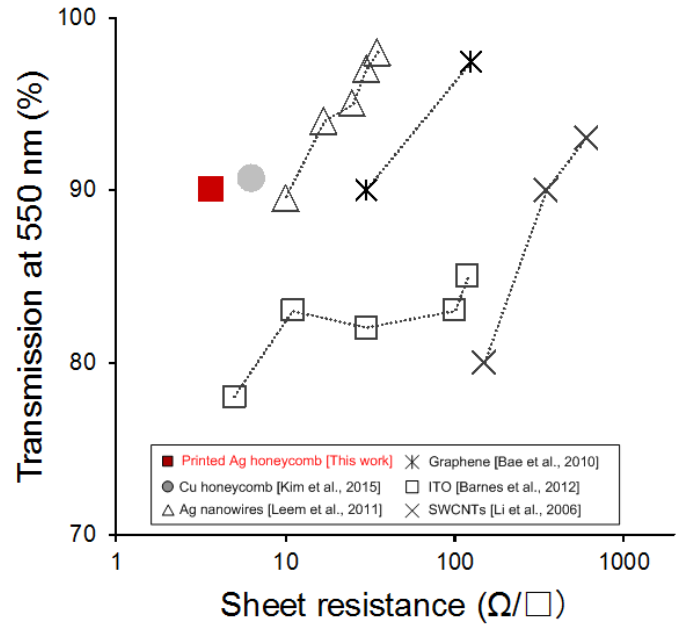
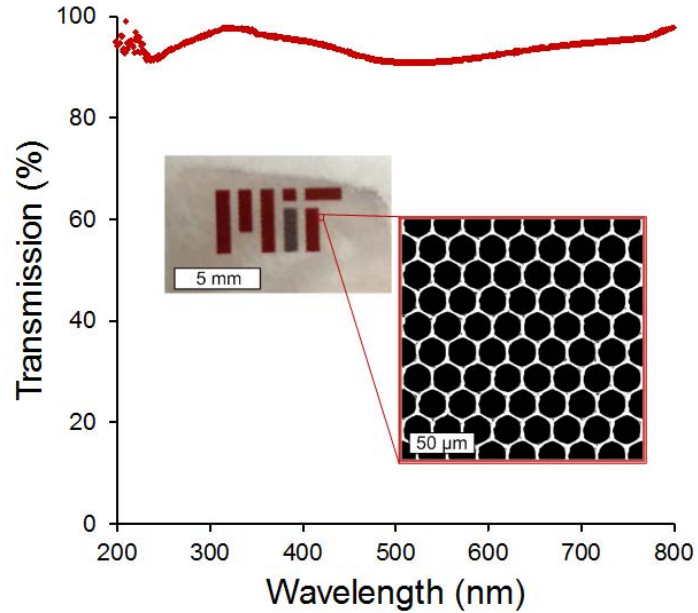



Contact mechanics of ink transfer

Probability density of fiber height on the stamp surface

$$\phi(l_{CNT}) = \frac{1}{\sigma_l \sqrt{2\pi}} \exp\left(-\frac{l_{CNT}^2}{2\sigma_l^2}\right)$$

Contact ratio

$$\frac{n_c}{n} = \int_d^\infty \phi(l_{CNT}) dl_{CNT} = \frac{1}{2} \left\{ 1 - \operatorname{erf}\left(\frac{d}{\sqrt{2}\sigma_l}\right) \right\}$$

Contact pressure

$$\begin{aligned} p &= \frac{1}{A} \sum_i^{n_c} P_{CNT,i} = \frac{1}{A} \sum_i^{n_c} k_{CNT} \delta_{CNT,i} = \frac{n}{A} \int_d^\infty k_{CNT} (l_{CNT} - d) \cdot \phi(l_{CNT}) dl_{CNT} \\ &= \frac{k_{CNT} \sigma_l}{\sqrt{2\pi} \lambda_{CNT}^2} \left[\exp\left(-\frac{d^2}{2\sigma_l^2}\right) - \sqrt{\frac{\pi}{2}} \frac{d}{\sigma_l} \left\{ 1 - \operatorname{erf}\left(\frac{d}{\sqrt{2}\sigma_l}\right) \right\} \right] \end{aligned}$$

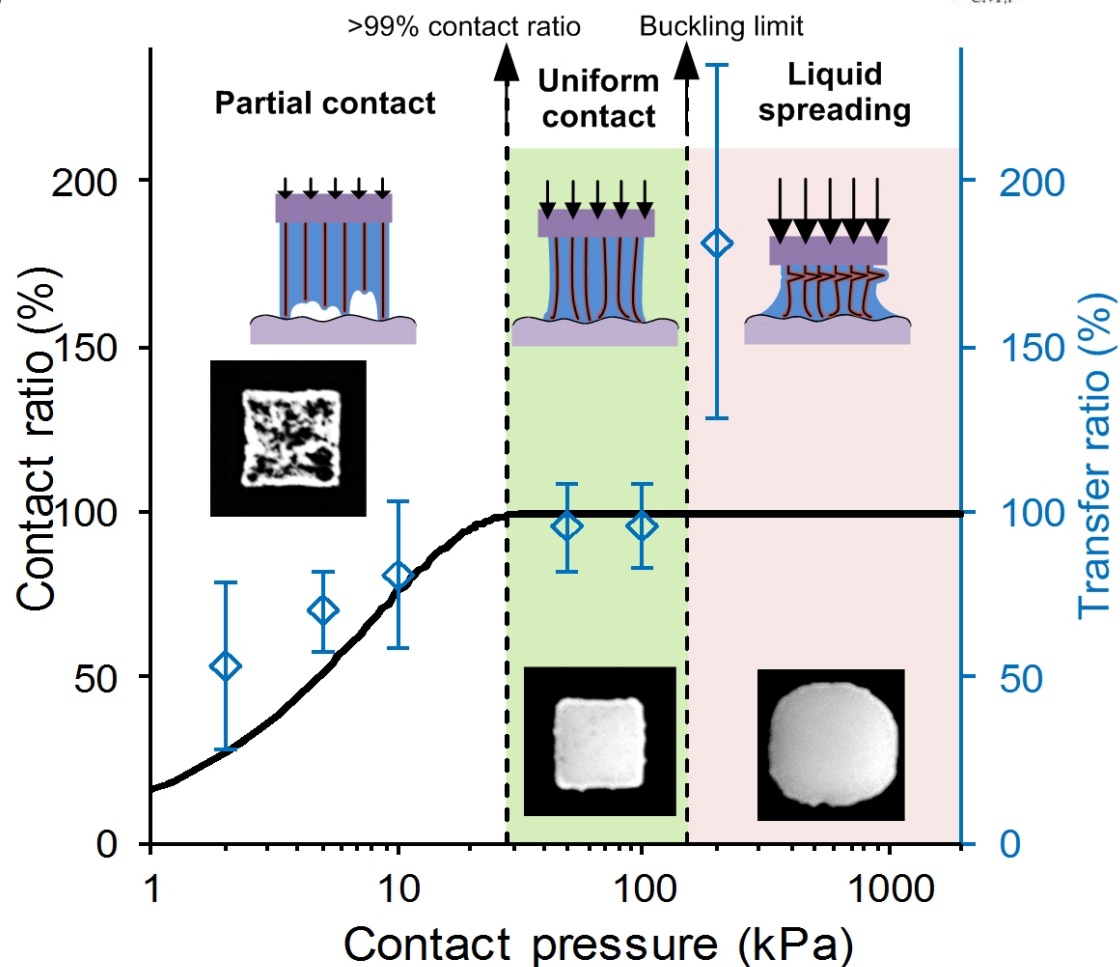
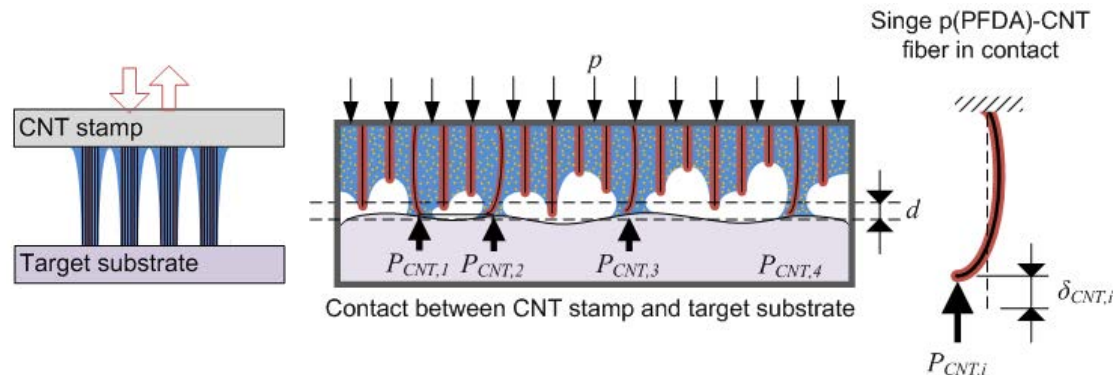



Ag nanoparticle ink

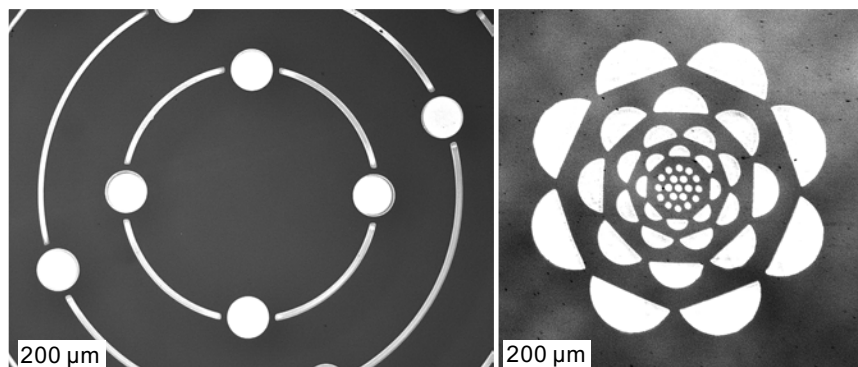

CdSe/ZnS quantum dot ink

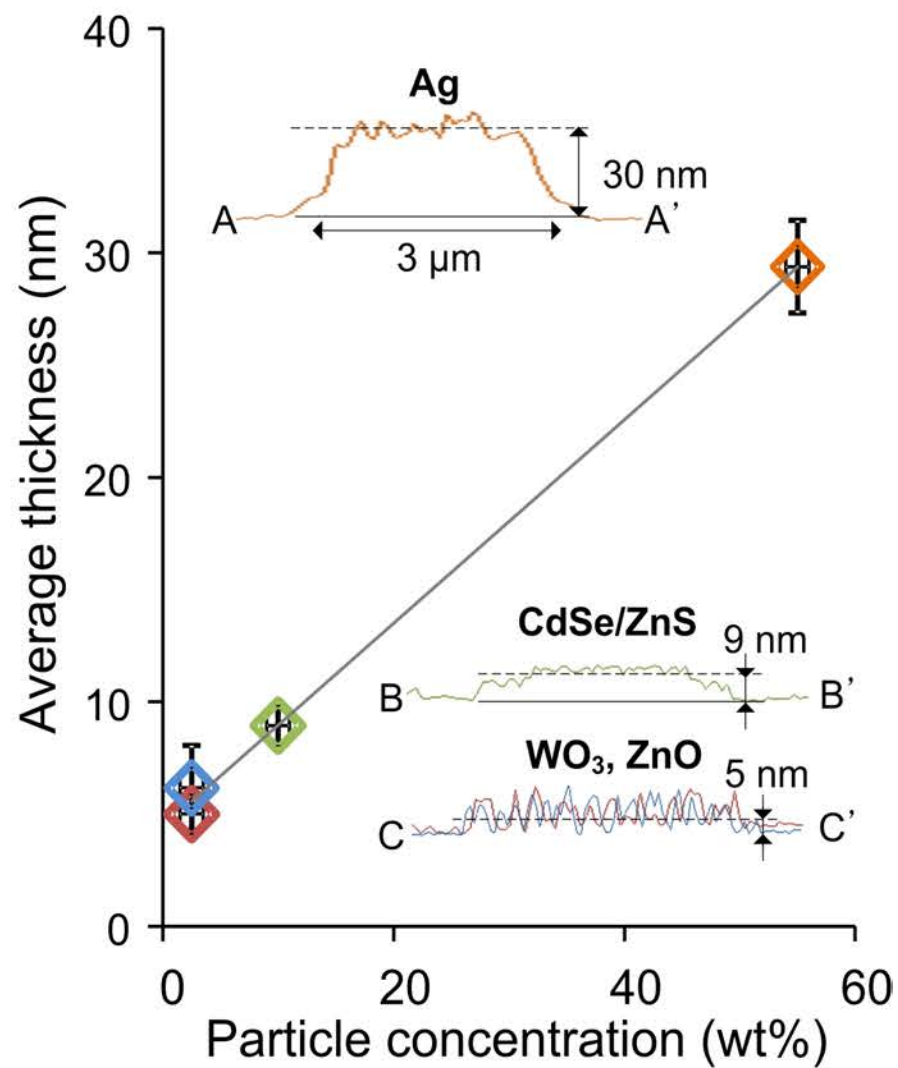
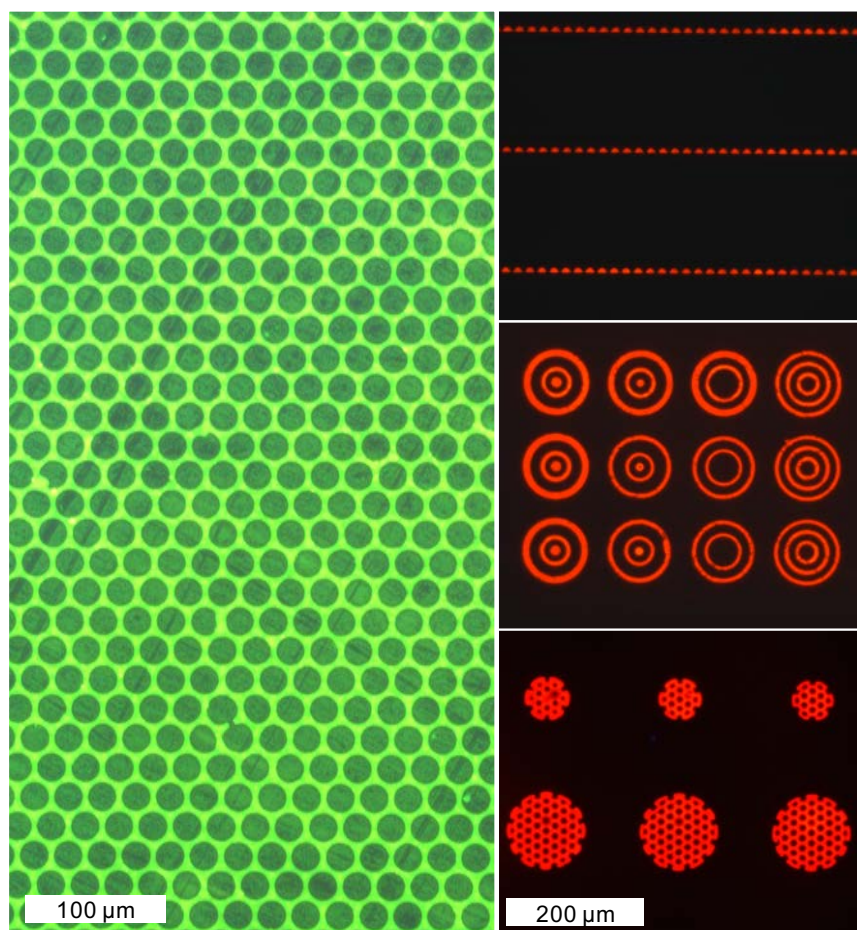

Vision: fully printed and flexible electronics



Flexible Thin Film Transistor (TFT) array

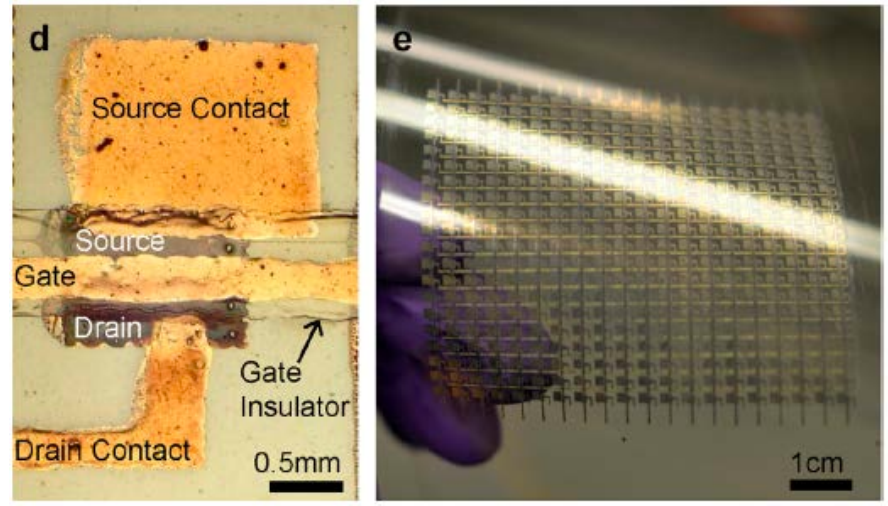

Gravure and inkjet printed TFT arrays [Lau et al., Nano Lett. 2013]

Organic Solar Cells

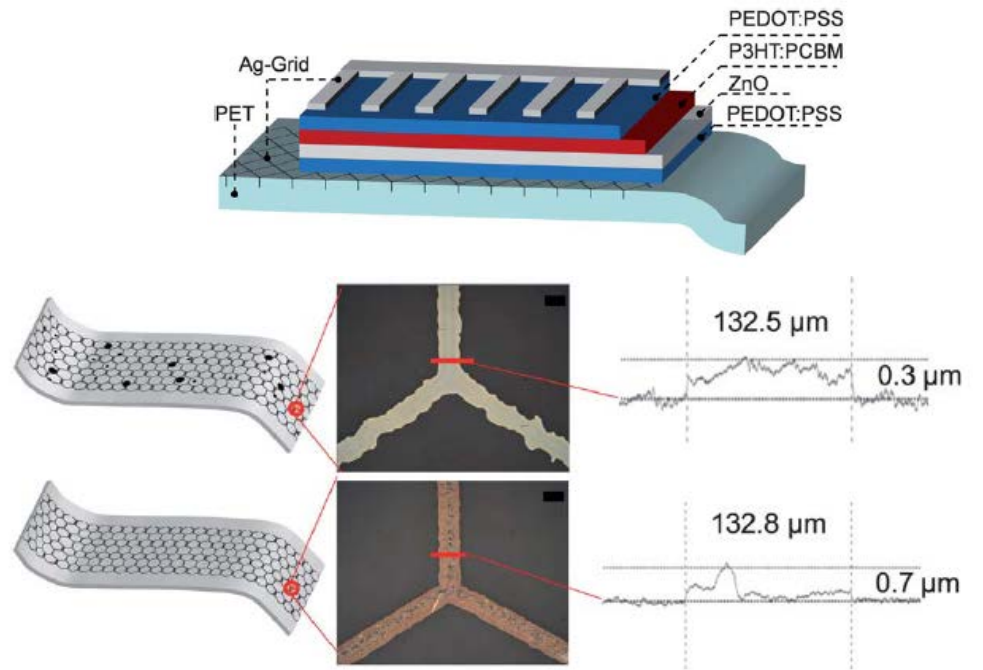

Inkjet (top) and flexographic (bottom) printed Ag grids [Yu et al., Nanoscale 2012]

Quantum dot (QD) displays

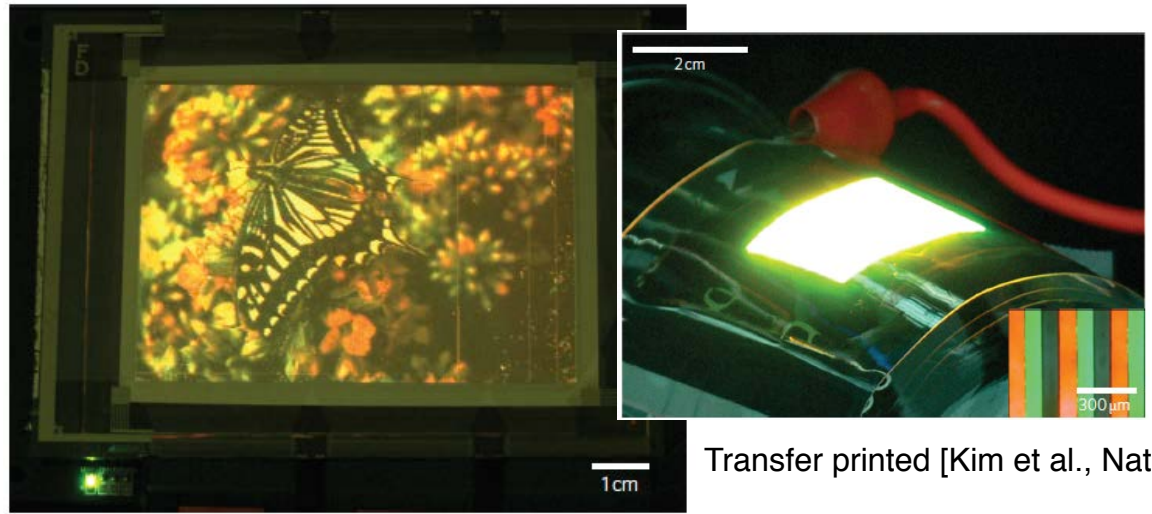
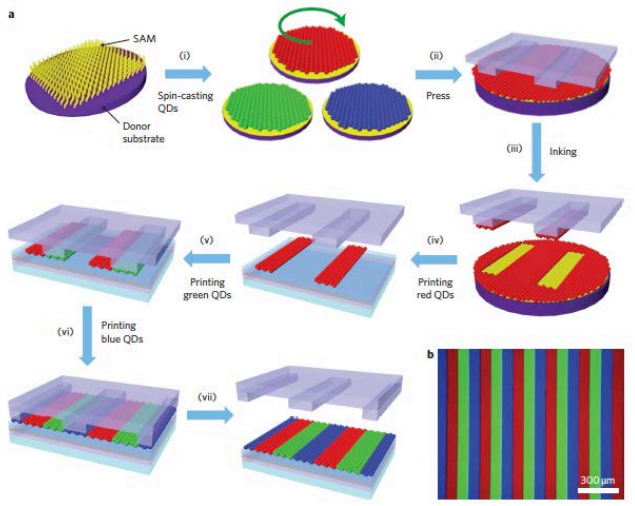

Transfer printed [Kim et al., Nat. phot. 2011]



Performance metrics

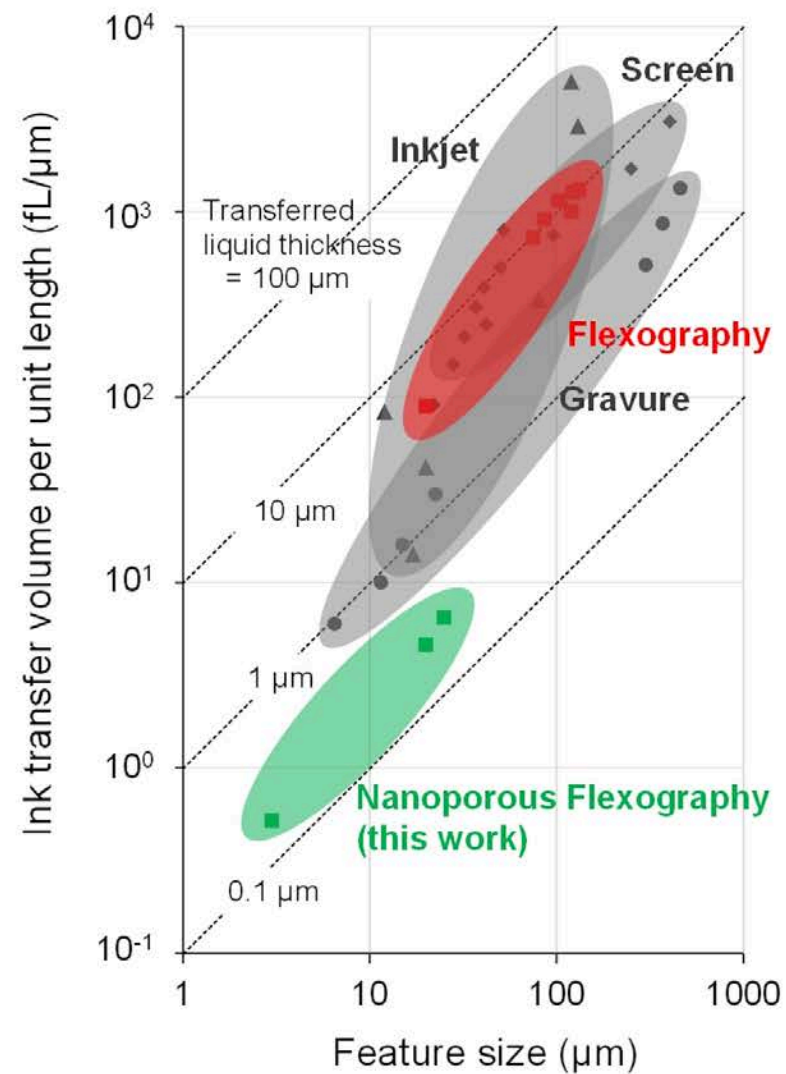
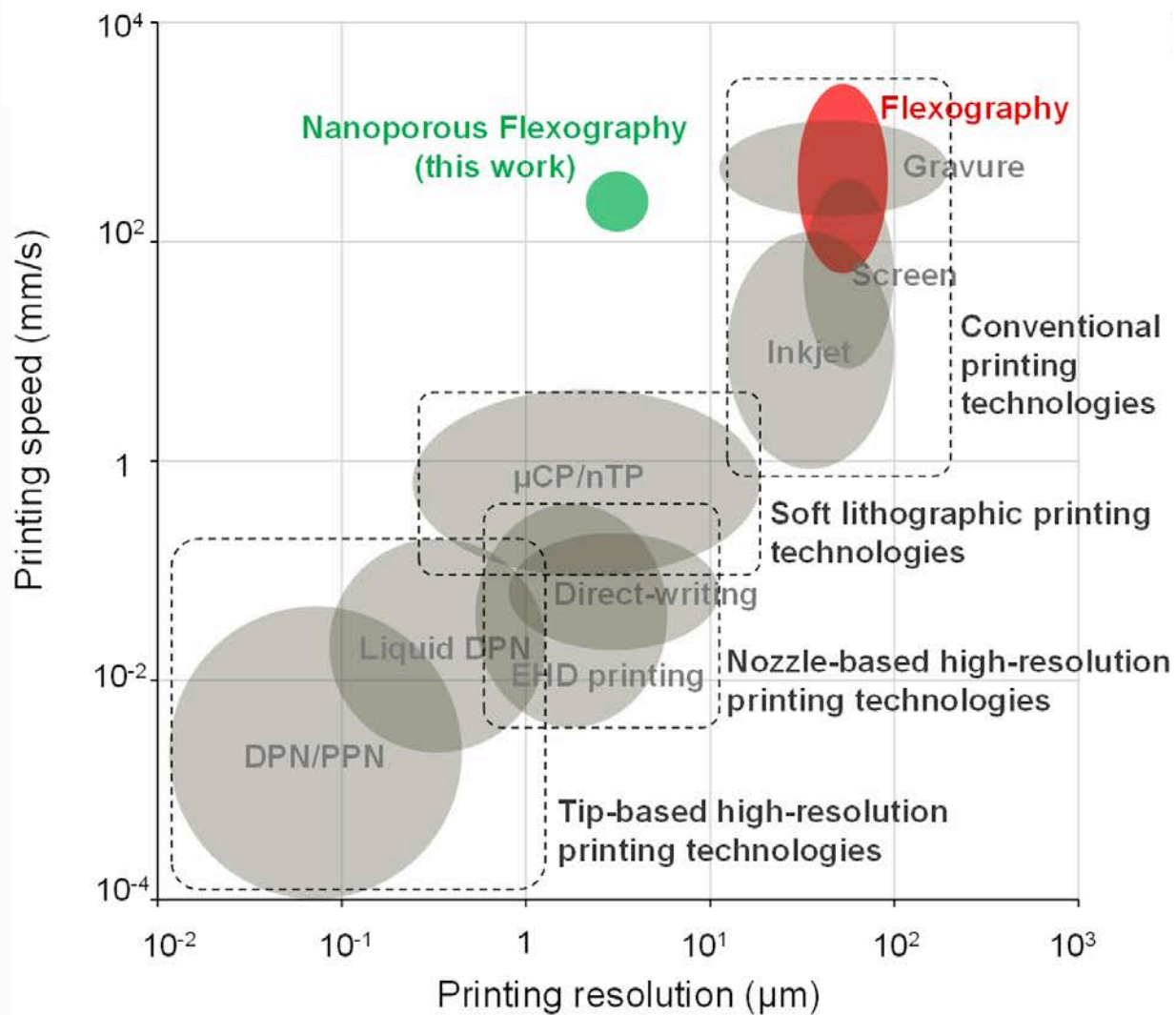

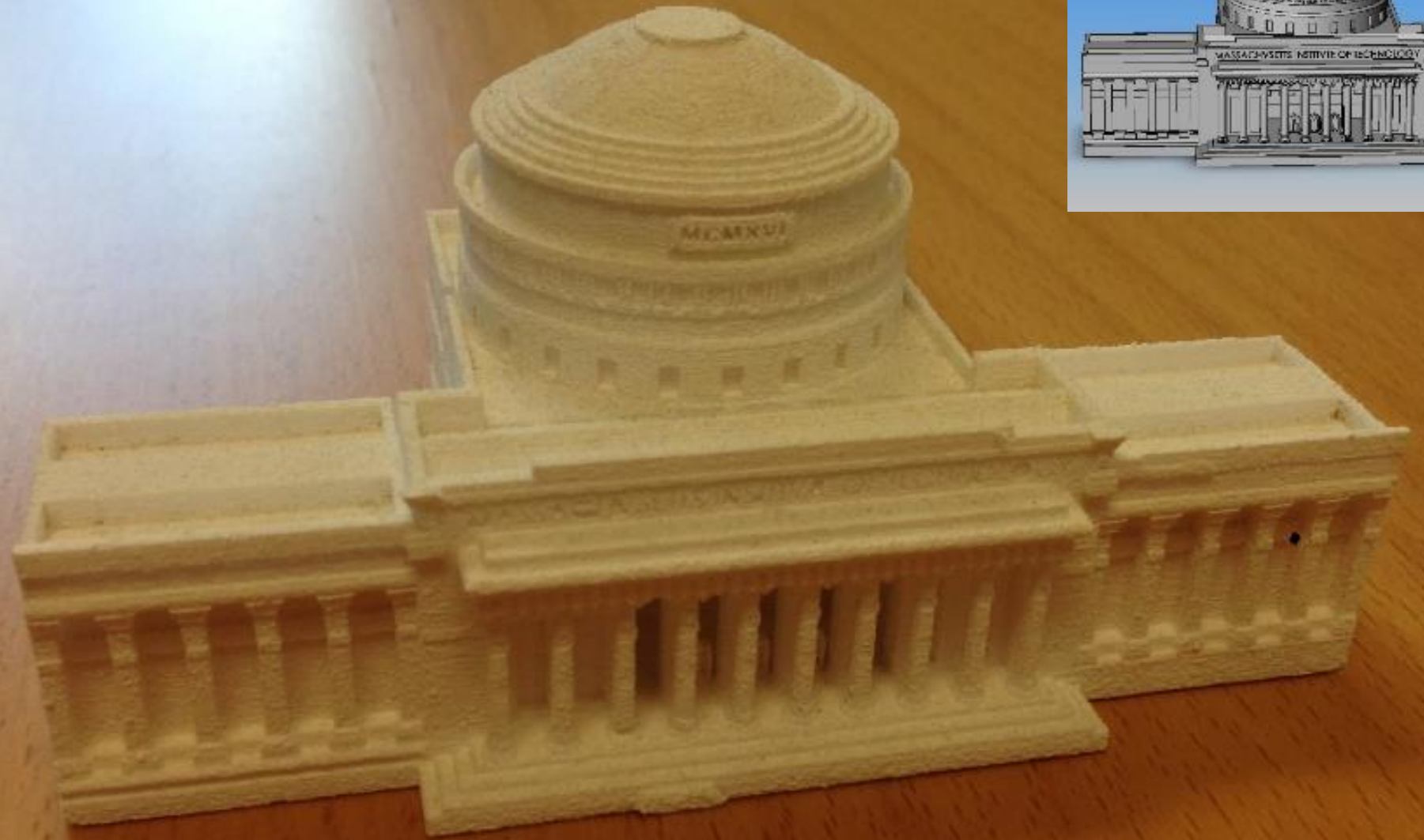
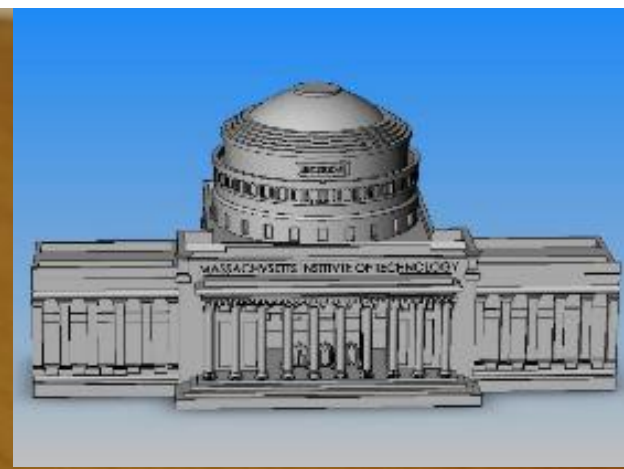

The AM industry today

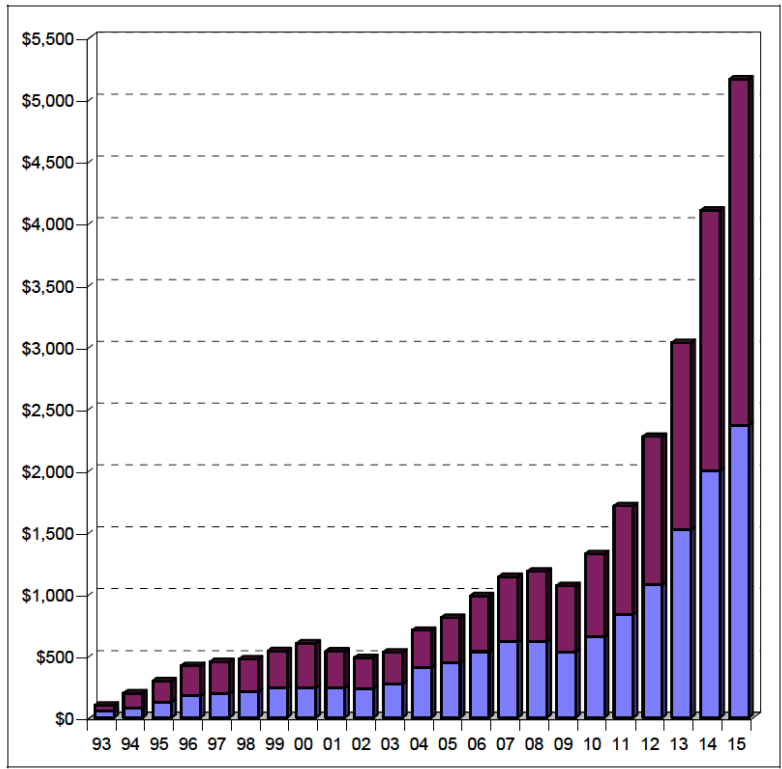

Services

Machines

2015: \$5.2B AM machines and services

2015 growth = 26%

27-year CAGR = 26%

Worldwide mfg is ~\$15 trillion (16% of the world economy)

AM = 0.03%.

Source: Wohlers Associates, Inc.

“How do you use the parts made on your industrial AM machines?”

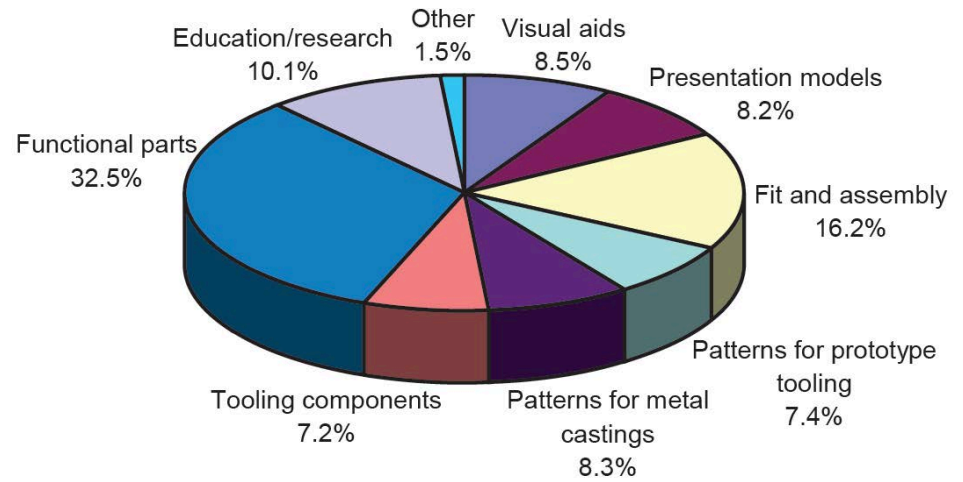

The diverse industrial uses of AM



GE fuel nozzle

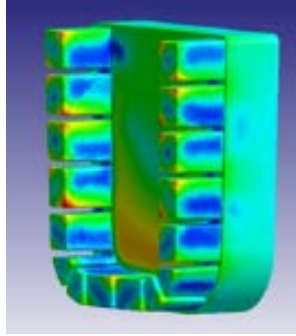
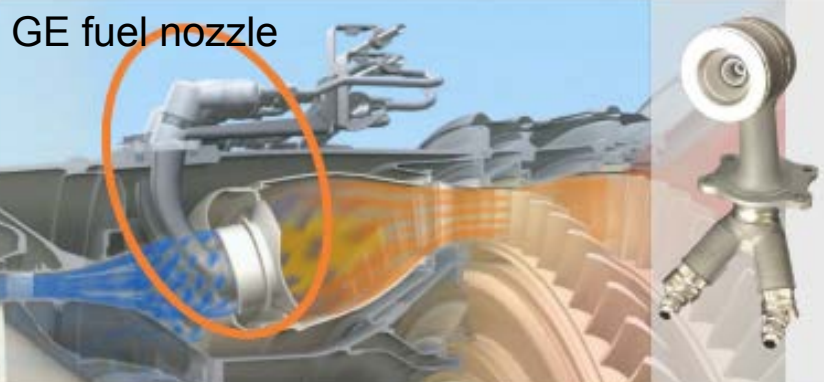

Shoe cleats (NIKE)



Airbus

Conventionally machined bracket (left) and redesigned bracket (right) using topology optimization, courtesy of Laser Zentrum Nord GmbH and Airbus



Tooling
Linear Mold, Triform

Skyfall



Modular products
(Google Ara)



Custom airway stent (U. Michigan)

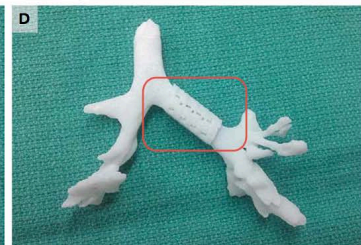
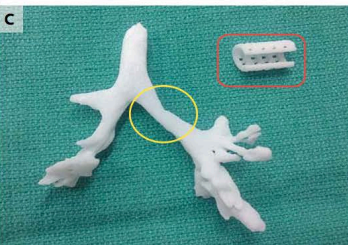

Fused Filament Fabrication (FFF)

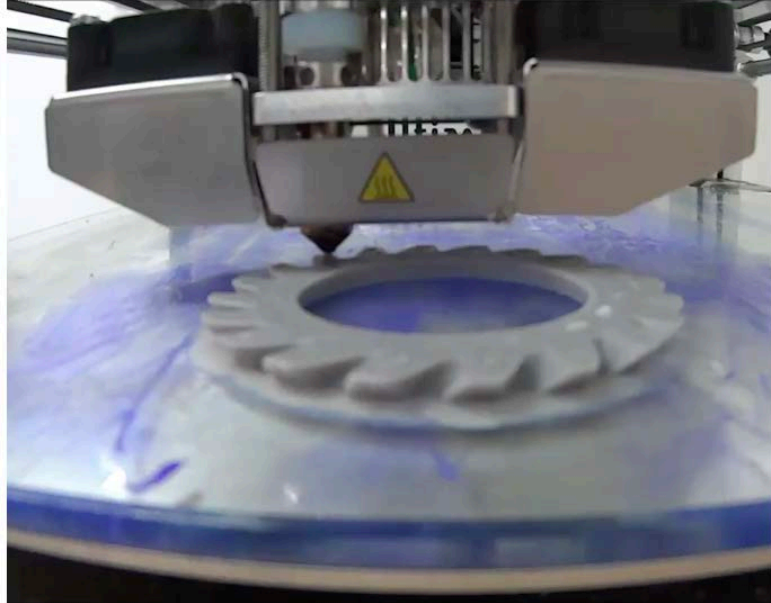
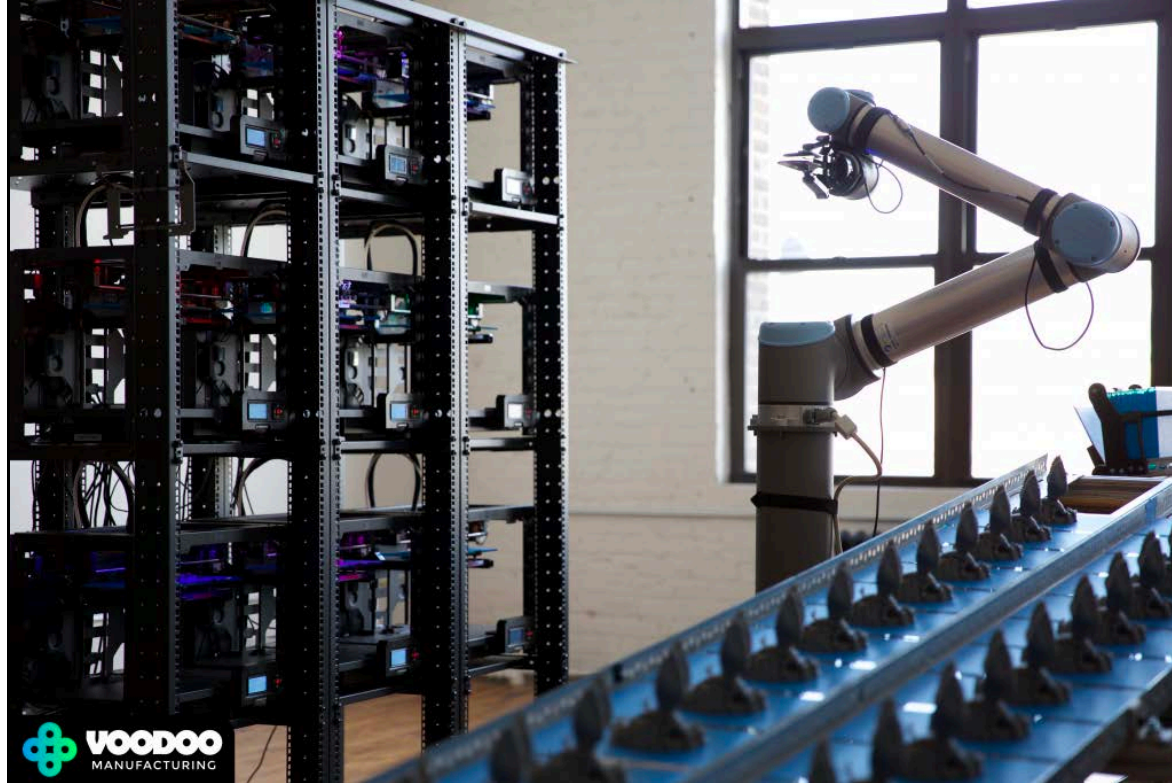
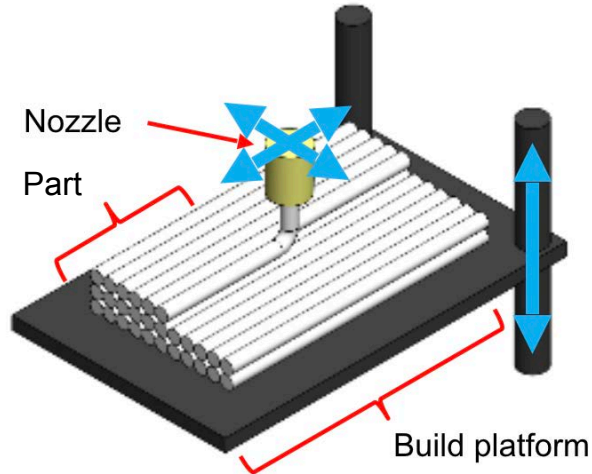

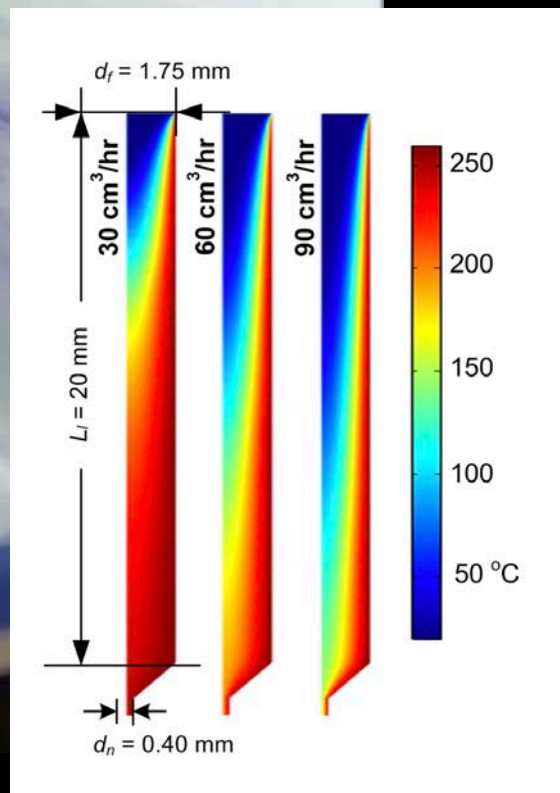
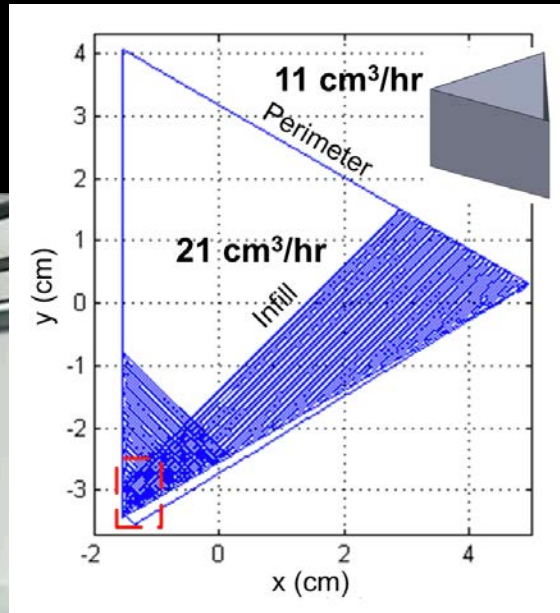
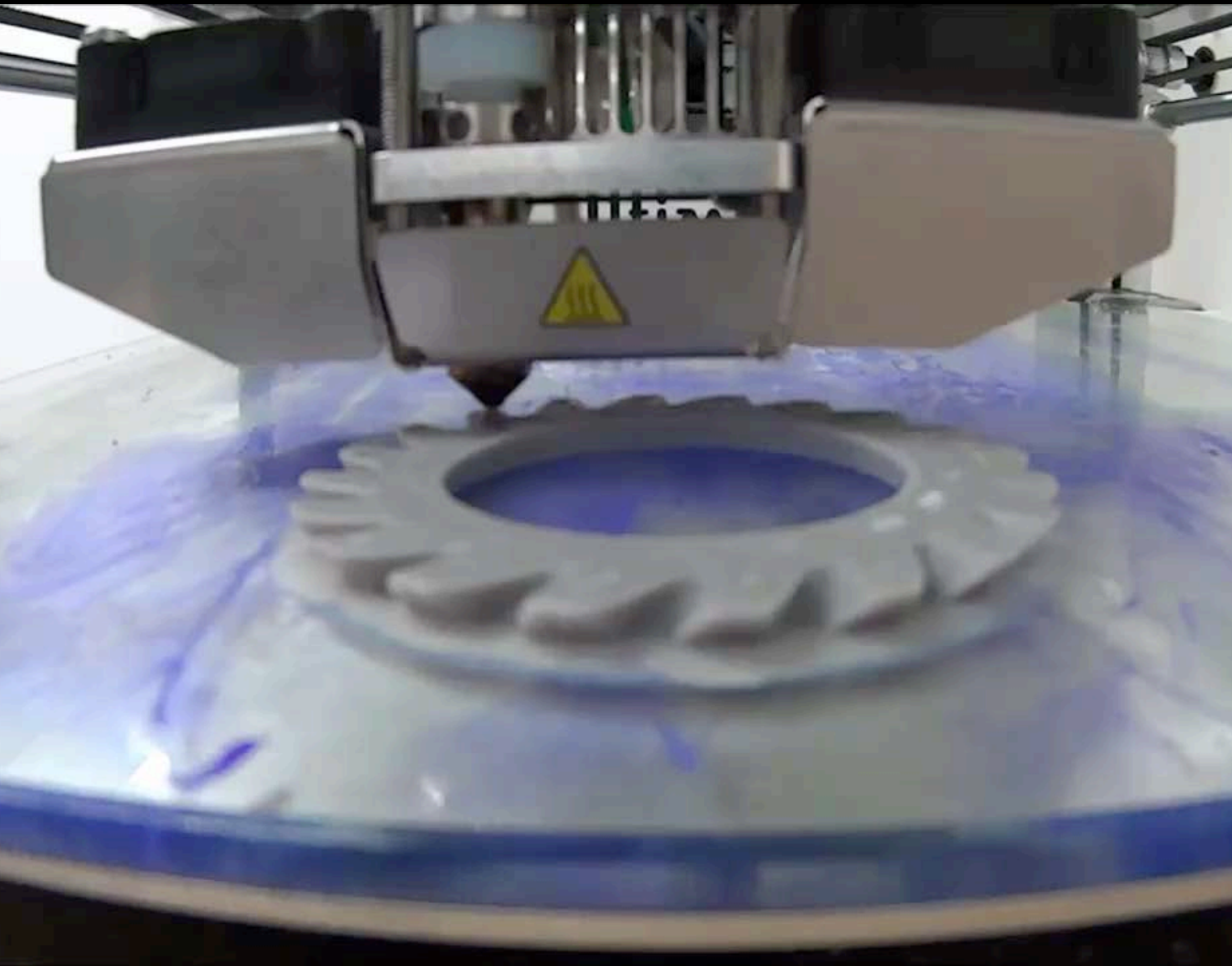

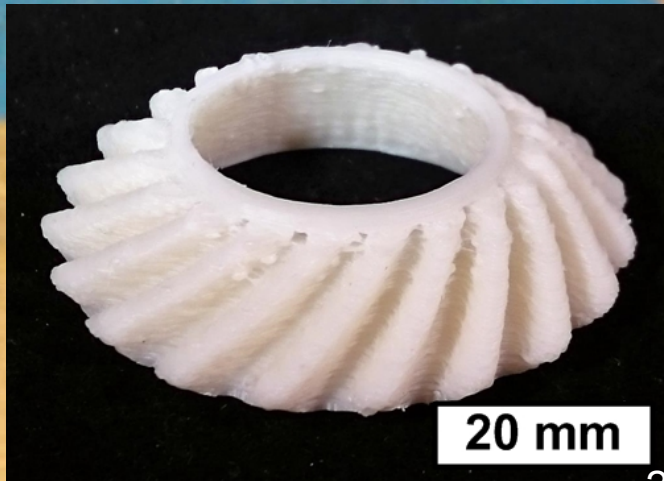
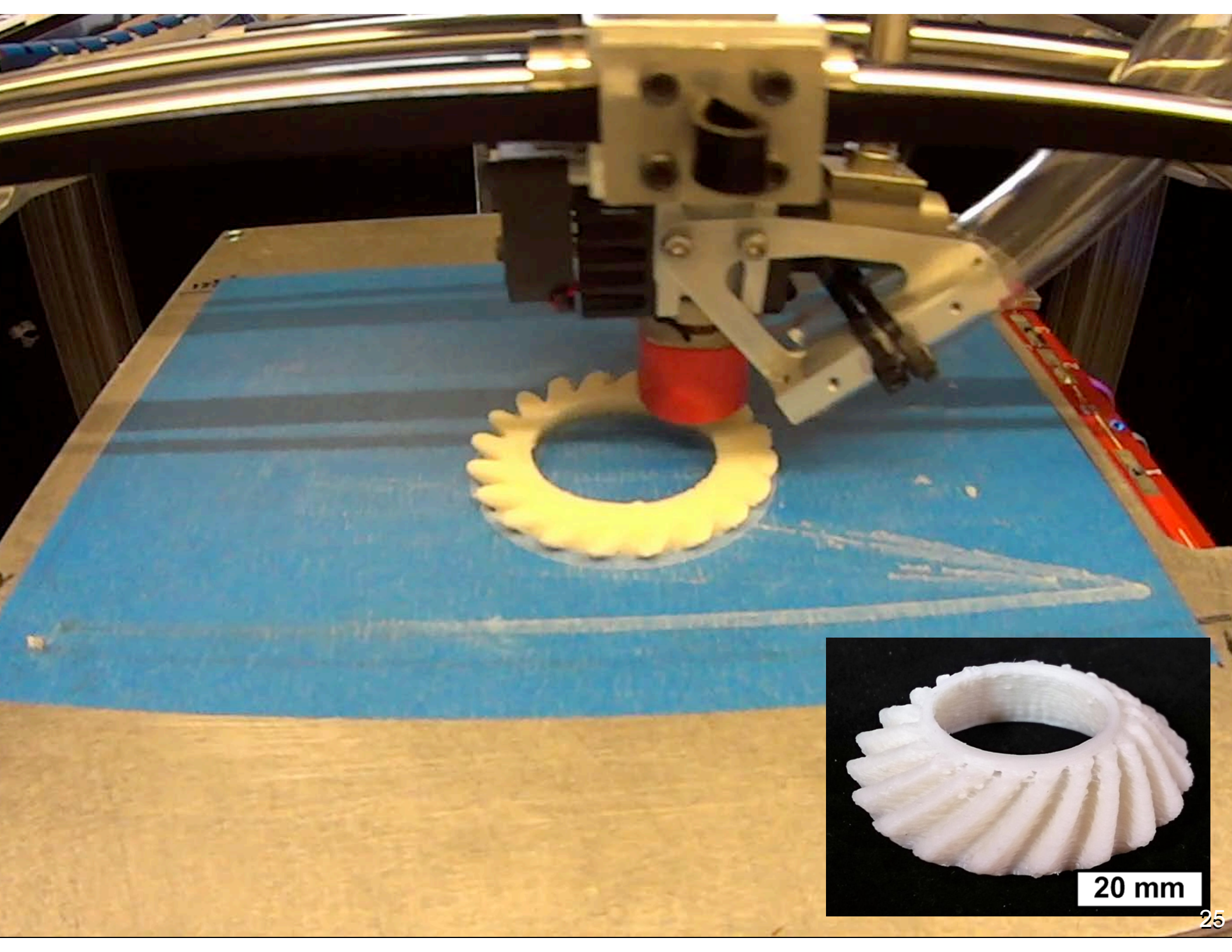

20 mm

FastFFF

Servo motors

H-frame gantry

Fume extractor

Print bed

Control electronics

Diode laser

Laser-safe enclosure

0.1 m



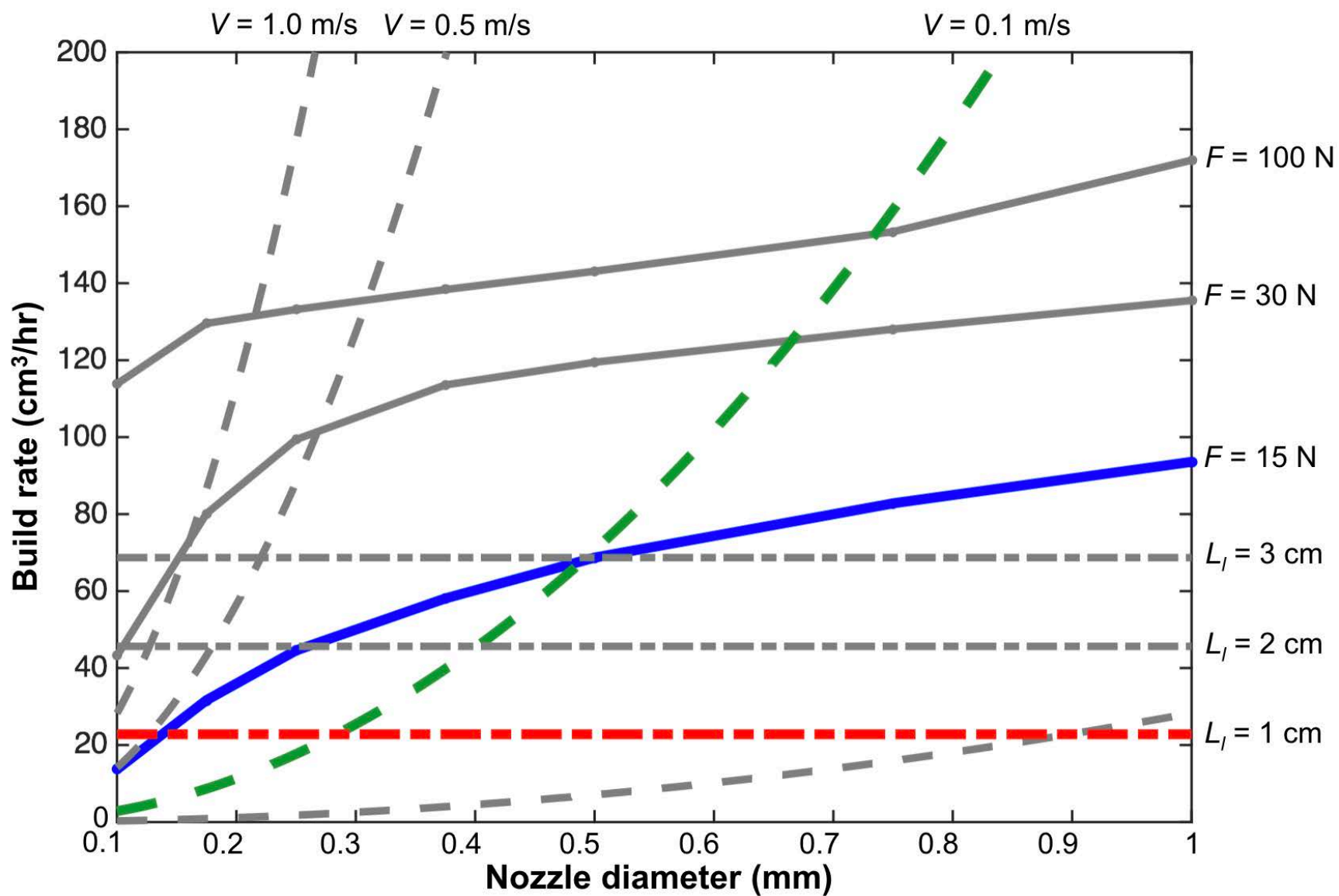
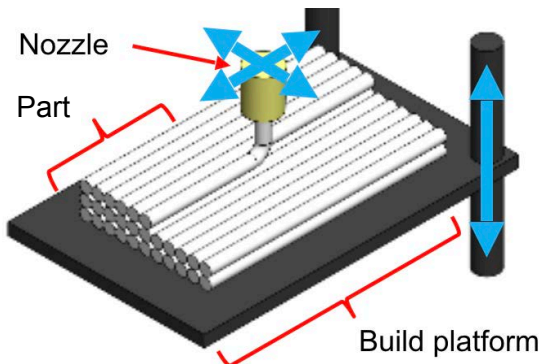

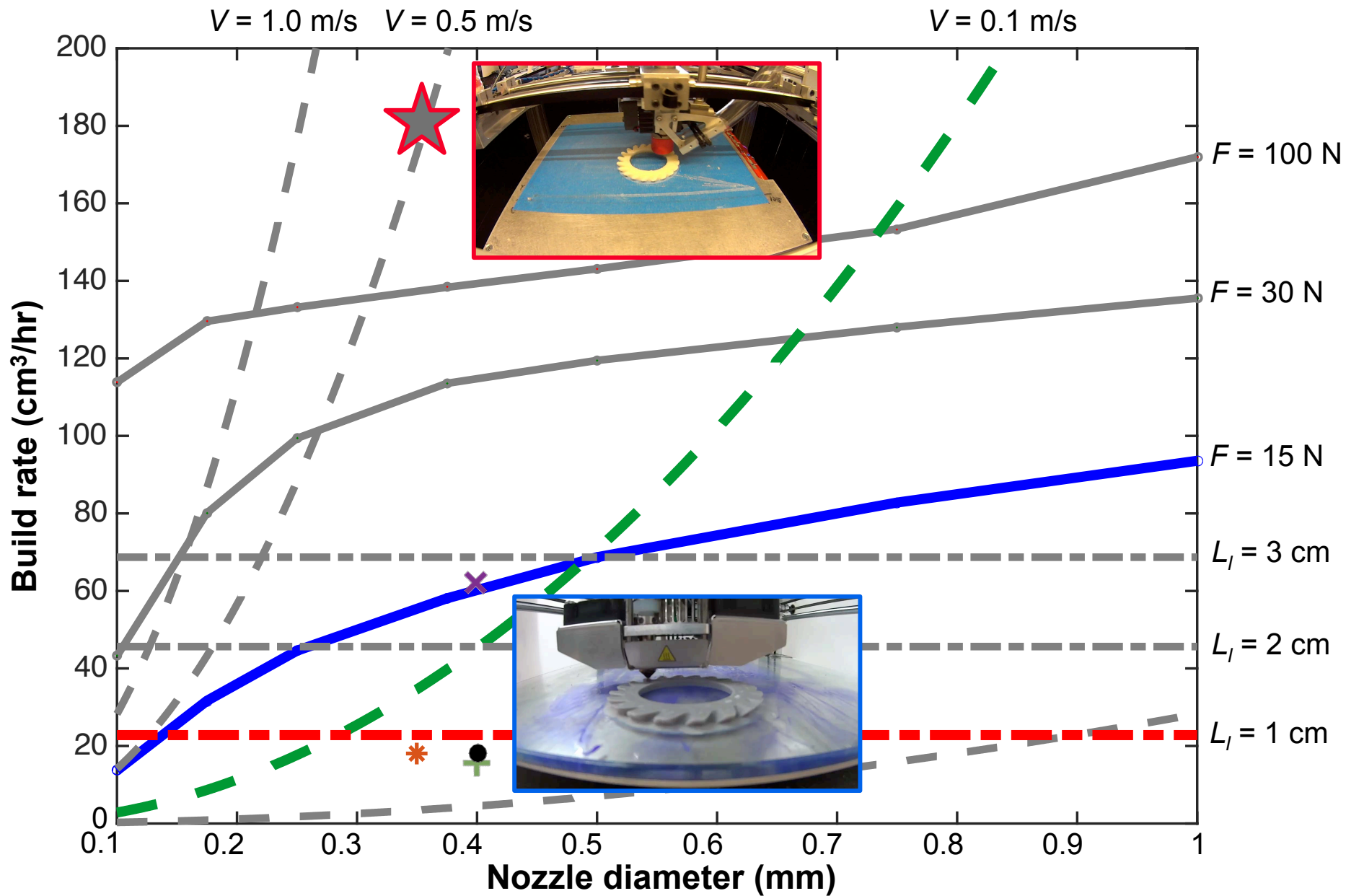



Raytheon RR-4, 1971.

What's next

Composite materials and high-performance resins

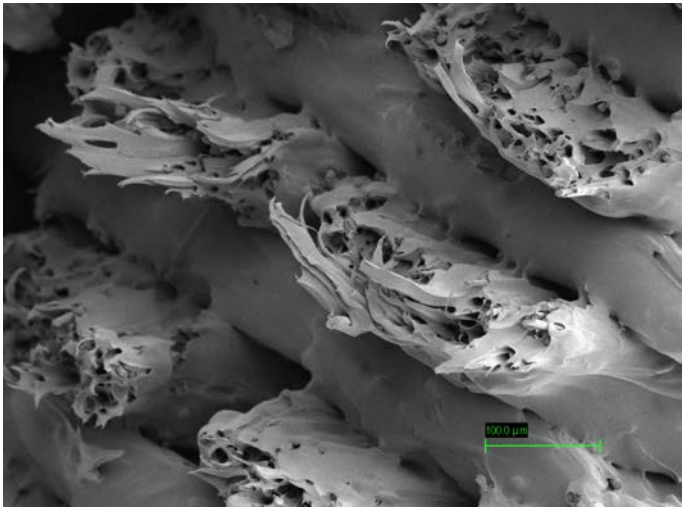
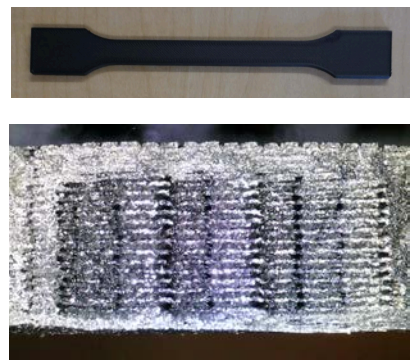

Scaled systems

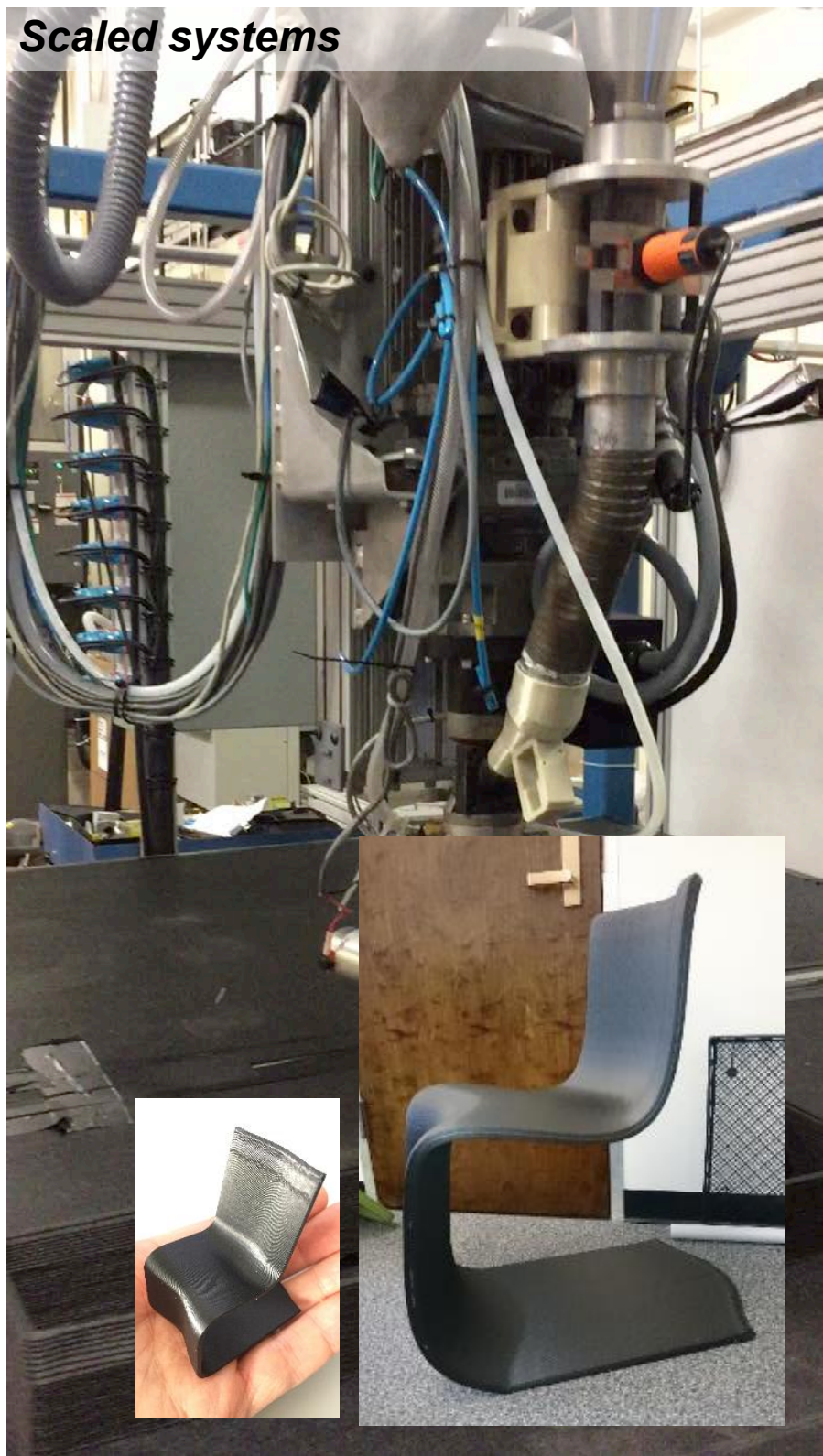

Toolpath optimization

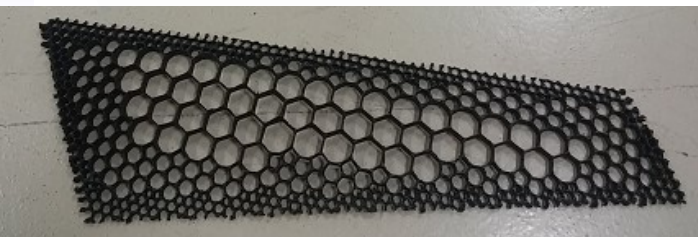
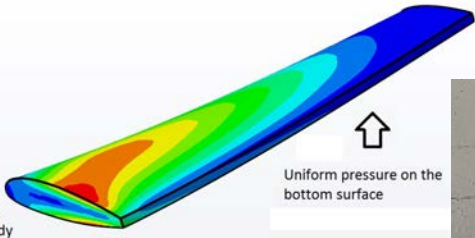
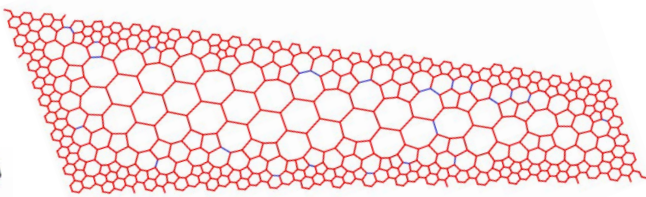

big
think



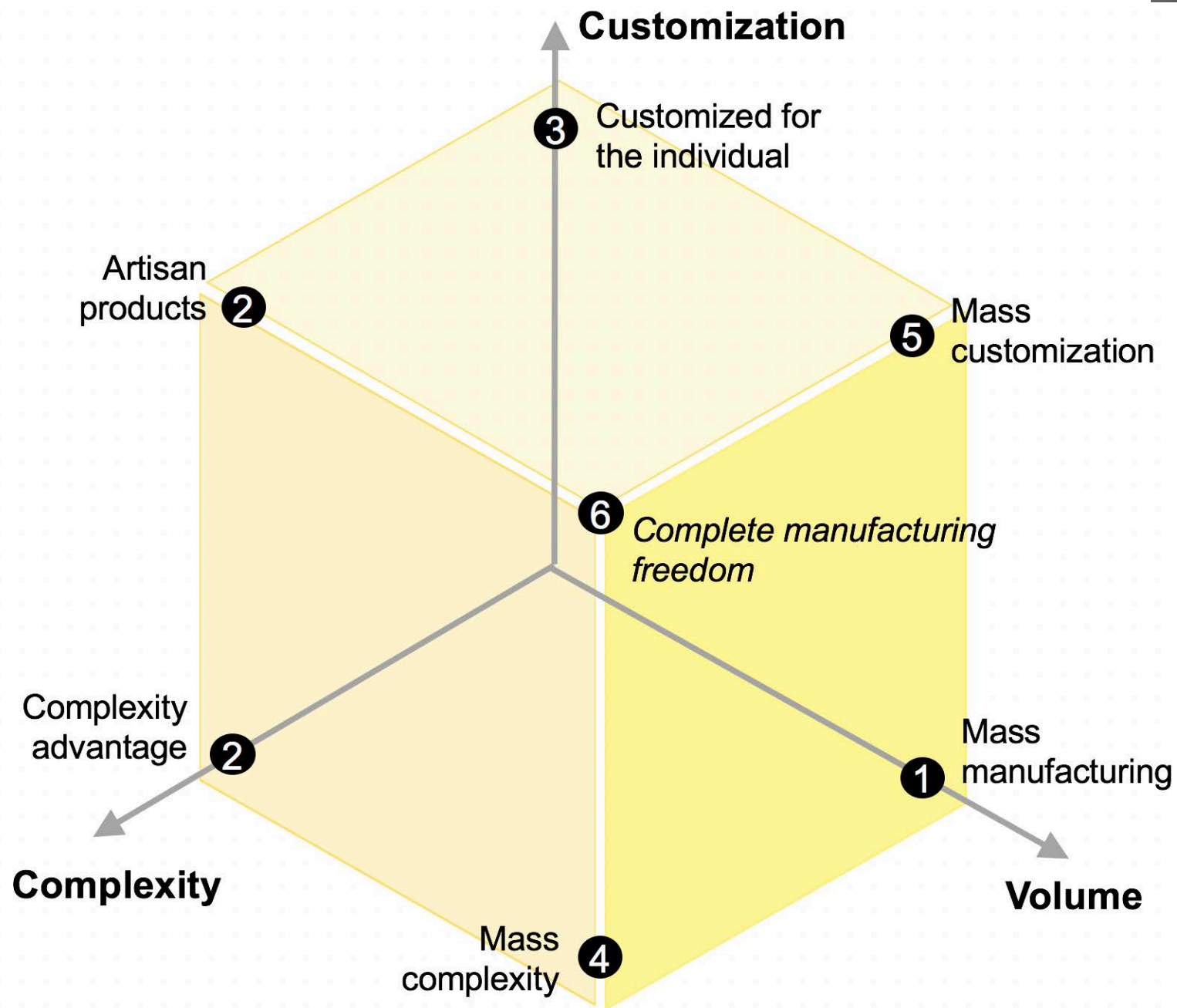

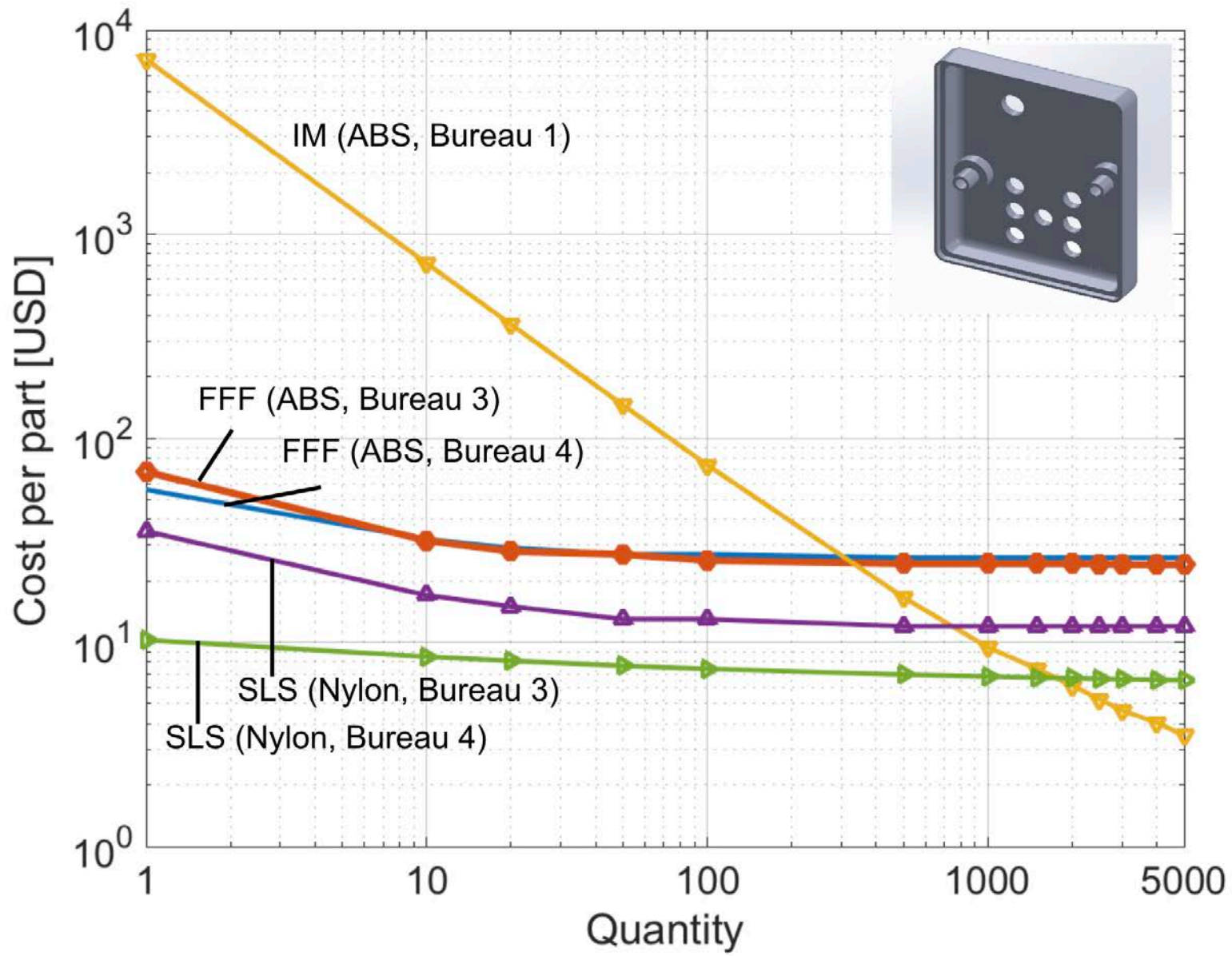



Desktop Metal is reinventing the way design and manufacturing teams print with metal.

We have developed a complete end-to-end printing system capable of producing parts at scale, from prototyping to mass production. Our technology seamlessly integrates hardware, software, and materials to exceed the current limitations of the industry and push the boundaries of what's possible with metal.



MIT | Center for Additive and Digital Advanced Production Technologies

<http://bit.ly/adapt-mit>
adaptcenter@mit.edu

Automation



Materials and Processes

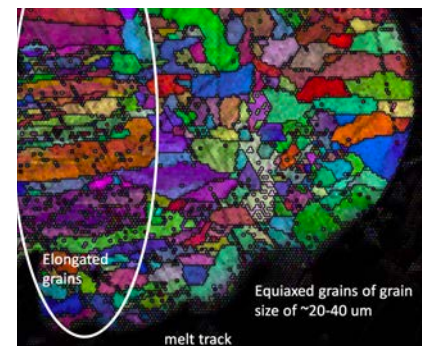
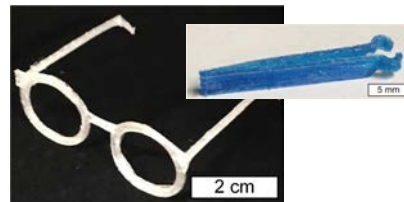
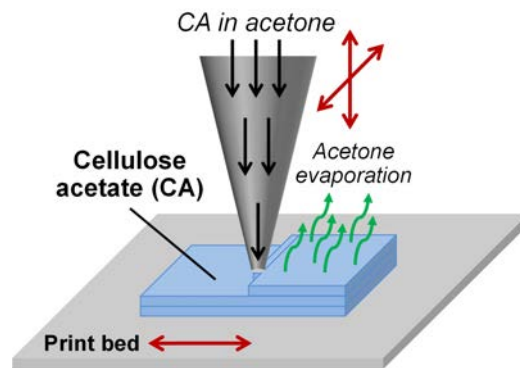

Optimization and Forecasting

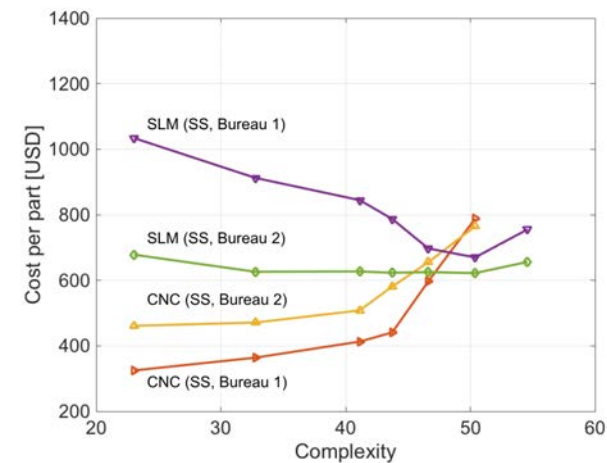
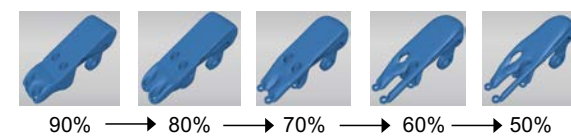



MIT | Center for Additive and Digital
Advanced Production Technologies

<http://bit.ly/adapt-mit>
adaptcenter@mit.edu

5-day course at MIT
**“Additive Manufacturing:
From 3D Printing to the
Factory Floor”**
July 31 - Aug 4, 2017
<http://bit.ly/3dmit>



Thank you

Flexoprinting: Sanha Kim, Hossein Sojoudi, Dhanush Mariappan, Hangbo Zhao, Gareth Mckinley, Karen Gleason

FastFFF: Jamison Go, Padraig Moloney, Scott Schiffres, Adam Stevens, Max Malinowski

Other projects: Justin Beroz, Crystal Owens, Ryan Penny, Talha Hasan

ADAPT: Haden Quinlan, John Jaddou

mechanosynthesis.mit.edu
ajhart@mit.edu

